

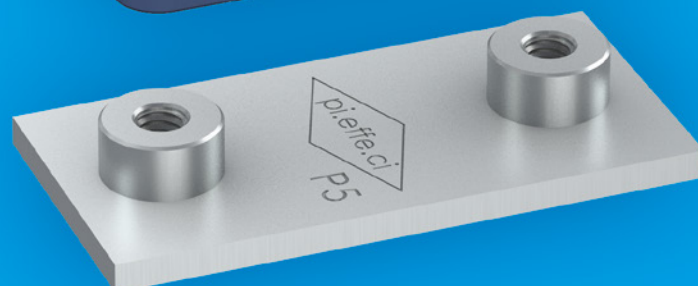

PIPE CLAMPS
STANDARD SERIES

14

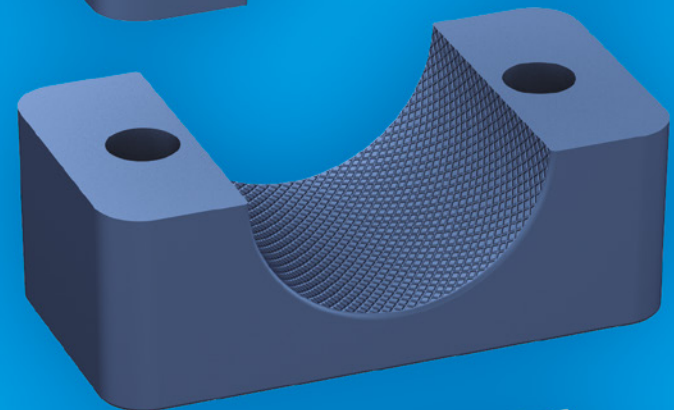

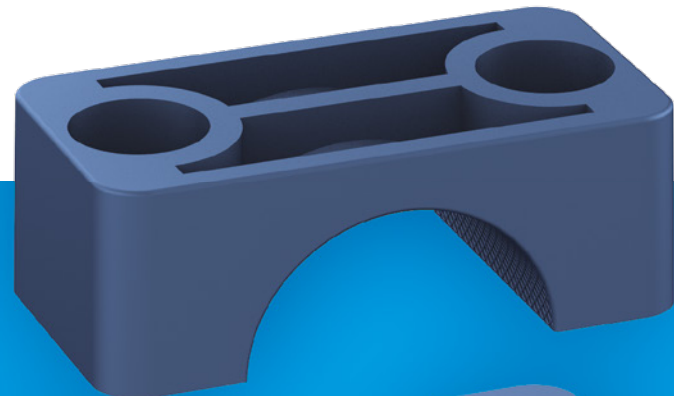
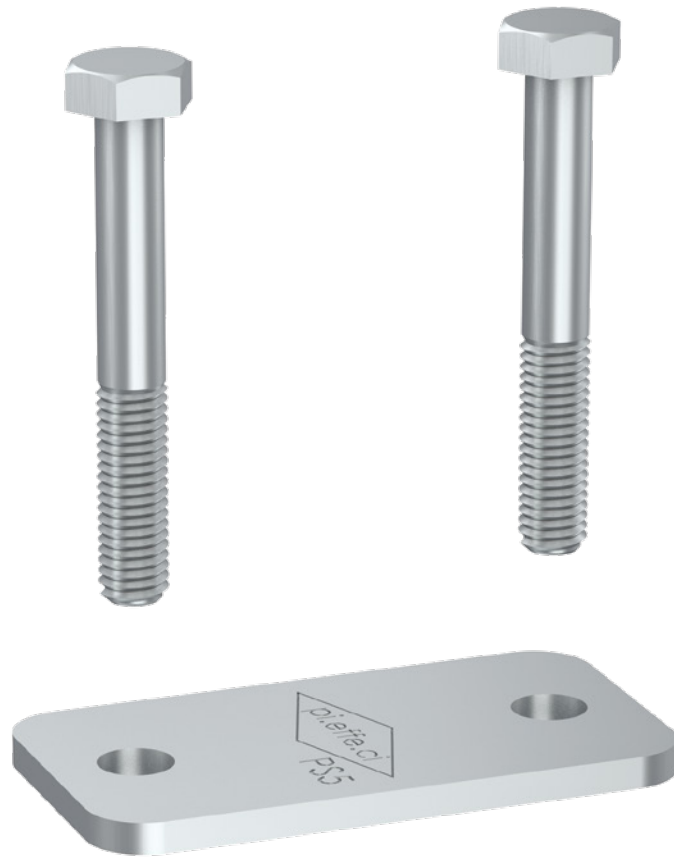
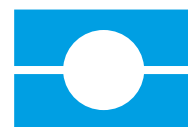

PIPE CLAMPS STANDARD SERIES

DIN 3015, PART 1

PIPE CLAMPS
STANDARD SERIES

15

CLAMP BODY STANDARD MATERIALS



Polypropylene
Colour **Blue**
Code **PP**

**OTHER COLOURS
AVAILABLE ON DEMAND!**



Polyamide
Colour **Black**
Code **PA**



Rubber Elastomer
Colour **Black**
Code **GM**



Self-extinguishing Polypropylene
Colour **White**
Code **AU**



Aluminium
Colour **Natural**
Code **A**

DIFFERENT DAMETERS AND MATERIALS AVAILABLE ON REQUEST.

Clamp body internal surface:
knurled (C1 to C7)
profiled (C8-C9, AC1 to AC7, C60, TG)
smooth (C7C, C1 L to C9 L)

For Material Characteristics, see Technical Appendix (page 147).

COMPONENTS AND ACCESSORIES STANDARD MATERIALS

Carbon Steel S 235 JR with finishing surface in white zinc-coated
Fe Zn c8 II.

Untreated are available on request.

Stainless Steel Inox 316L (X2 CrNiMo 17-12-2) 1.4404
marked with X identification code.

The **BB** track is treated with zinc-plating SENDZIMIR.
The **BBP** track is treated with zinc-coating Fe Zn c8 II.

Metric thread: code **M**
UNC thread: code **UNC**.

For Material Characteristics, see Technical Appendix (page 147).





C CLAMP BODY

TWO CLAMP HALVES

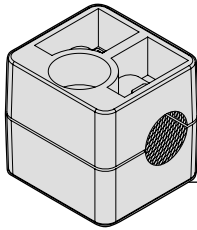

TYPE 1

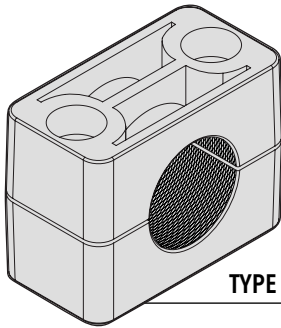

TYPE 2 TO 9

DIN 3015, PART 1

PIPE CLAMPS
 STANDARD SERIES

16

Code C (Material PP - PA - GM - AU)
 Code AC (Material AL).

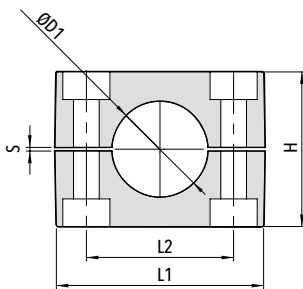
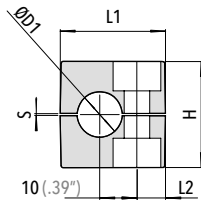

ORDER CODE

CLAMP BODY CODE	OUTSIDE DIAMETER (mm)	MATERIAL
-----------------	-----------------------	----------

EXAMPLE

Clamp body type: 3
 Material: PP
 Outside diameter: 15 mm
 Order code: **C3 - 15 - PP**

Code	Outside Diameter ØD1		L1	L2	H	S	Width
	mm	nominal bore pipe in					
C1 AC1	6		28 (1.10")	9,5 (.37")	27 (1.06")	0,6 (.02")	30 (1.18")
	6,4	1/4"					
	8	5/16"					
	9,5	3/8"					
	10	1/8"					
	12						
C2 AC2	12,7	1/2"					
	6		37 (1.46")	20 (.79")	27 (1.06")	0,6 (.02")	30 (1.18")
	6,4	1/4"					
	8	5/16"					
	9,5	3/8"					
	10	1/8"					
12							
C3 AC3	12,7	1/2"					
	13,5	1/4"					
	14		42 (1.65")	26 (1.02")	33 (1.30")	0,8 (.03")	30 (1.18")
	15						
	16	5/8"					
	17,2	3/8"					
18							
C4 AC4	19	3/4"					
	20		50 (1.97")	33 (1.30")	36 (1.42")	0,8 (.03")	30 (1.18")
	21,3	1/2"					
	22	7/8"					
	23						
	25						
25,4	1"						
C5 AC5	26,9	3/4"					
	28		57 (2.24")	40 (1.57")	42 (1.65")	1 (.04")	30 (1.18")
	29						
	30						
	32	1.1/4"					
	C6 AC6	32					
33,7		1"					
35			71 (2.80")	52 (2.05")	58 (2.28")	1,4 (.05")	30 (1.18")
38		1.1/2"					
40							
42,4		1.1/4"					
45							
44,5	1.3/4"						
C7 AC7	45		86 (3.39")	66 (2.60")	66 (2.60")	1,4 (.05")	30 (1.18")
	48,3	1.1/2"					
	50						
	50,8	2"					
	53						
	54	1.3/4"					
C8	57,2	2.1/4"					
	60,3	2"					
	63,5	2.1/2"					
	66		121 (4.76")	94 (3.70")	93 (3.66")	2 (.08")	30 (1.18")
	70	2.3/4"					
	73						
76,1	2.1/2"						
77							
78,1	3"						
C9	83,5		147 (5.79")	120 (4.72")	118 (4.65")	3 (.1")	30 (1.18")
	88,9	3"					
	102	3.1/2"					



CL CLAMP BODY

CLAMPS SMOOTH INSIDE SURFACE WITHOUT TENSION CLEARANCE

TWO CLAMP HALVES SUITABLE FOR THE INSTALLATION OF HOSES OR CABLES

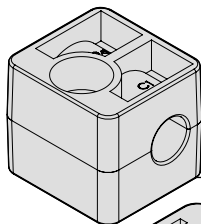

TYPE 1

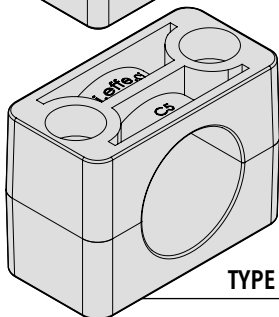

TYPE 2 TO 9

Code C L (Material PP - PA - GM - AU)

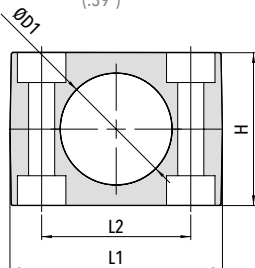
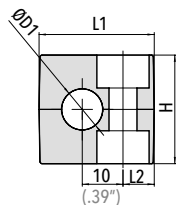

Code	Outside Diameter ØD1		L1	L2	H	Width
	mm	nominal bore pipe in				
C1 L	6		28 (1.10")	9,5 (.37")	26 (1.02")	30 (1.18")
	6,4	1/4"				
	8	5/16"				
	9,5	3/8"				
	10	1/8"				
C2 L	12		37 (1.46")	20 (.79")	26 (1.02")	30 (1.18")
	12,7	1/2"				
	6					
	6,4	1/4"				
	8	5/16"				
C3 L	9,5	3/8"	42 (1.65")	26 (1.02")	32 (1.26")	30 (1.18")
	10	1/8"				
	12					
	12,7	1/2"				
	13,5	1/4"				
C4 L	14		50 (1.97")	33 (1.30")	35 (1.38")	30 (1.18")
	15					
	16	5/8"				
	17,2	3/8"				
	18					
C5 L	19	3/4"	57 (2.24")	40 (1.57")	41 (1.6")	30 (1.18")
	20					
	21,3	1/2"				
	22	7/8"				
	23					
C6 L	25		71 (2.80")	52 (2.05")	56,5 (2.22")	30 (1.18")
	25,4	1"				
	26,9	3/4"				
	28					
	29					
C7 L	30		86 (3.39")	66 (2.60")	64,5 (2.54")	30 (1.18")
	32	1.1/4"				
	32	1.1/4"				
	33,7	1"				
	35					
C8 L	38	1.1/2"	121 (4.76")	94 (3.70")	91 (3.58")	30 (1.18")
	40					
	42,4	1.1/4"				
	45					
	44,5	1.3/4"				
C9 L	45		147 (5.79")	120 (4.72")	115 (4.53")	30 (1.18")
	48,3	1.1/2"				
	50					
	50,8	2"				
	53					
C8 L	54	1.3/4"	121 (4.76")	94 (3.70")	91 (3.58")	30 (1.18")
	57,2	2.1/4"				
	60,3	2"				
	63,5	2.1/2"				
	66					
C9 L	70	2.3/4"	147 (5.79")	120 (4.72")	115 (4.53")	30 (1.18")
	73					
	76,1	2.1/2"				
	83,5					
	88,9	3"				
C9 L	102	3.1/2"	147 (5.79")	120 (4.72")	115 (4.53")	30 (1.18")
		4"				

DIN 3015, PART 1
PIPE CLAMPS
STANDARD SERIES

ORDER EXAMPLE

C5 L - 28 - PP





CB CLAMP BODY

WITH RUBBER BUSHING

TWO CLAMP HALVES

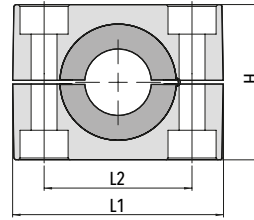
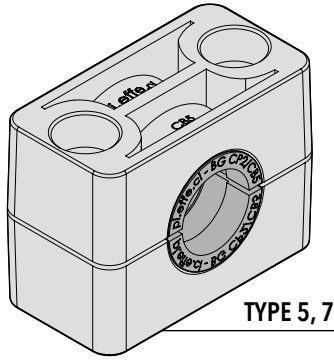

Code	L1	L2	H	Width
------	----	----	---	-------

CB5	57 (2.24")	40 (1.57")	42 (1.65")	30 (1.18")
------------	---------------	---------------	---------------	---------------

CB7	86 (3.39")	66 (2.60")	66 (2.60")	30 (1.18")
------------	---------------	---------------	---------------	---------------

ORDER EXAMPLE

CB5 - PP

Code CB (Material PP - PA - AU)

18

BG RUBBER BUSHING

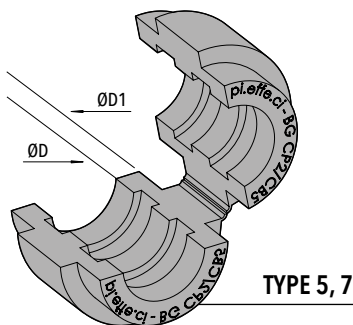

Code BG (Material GM)

Code	Outside Diameter ØD		ØD1	Width
	mm	nominal bore pipe in		

	6			
	8	5/16"		
	10	1/8"		
	12			
	12,7	1/2"		
BG CB5	14		25 (.98")	30 (1.18")
	15			
	16	5/8"		
	17,2	3/8"		
	18			
	19	3/4"		
	20			
	21,3	1/2"		
	22	7/8"		
BG CB7	25		38 (1.50")	30 (1.18")
	26,9	3/4"		
	28			
	30			
	32	1.1/4"		

ORDER EXAMPLE

BG CB5 - 15



CTG CLAMP BODY

FOR TWIN PIPES

TWO CLAMP HALVES

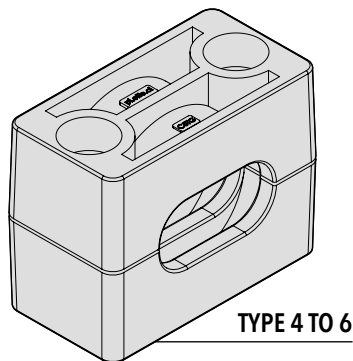
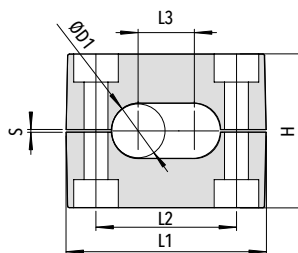

TYPE 4 TO 6

Code	Outside Diameter ØD		L1	L2	L3	H	S	Width
	mm	in						
C4 TG	10-10	.39"-.39"	50 (1.97")	33 (1.30")	10 (.40")	36 (1.42")	0,8 (.03")	30 (1.18")
	12-12	.47"-.47"			12 (.47")			
C5 TG	14-14	.55"-.55"	57 (2.24")	40 (1.57")	14 (.55")	42 (1.65")	1 (.04")	30 (1.18")
	16-16	.63"-.63"			16 (.63")			
C6 TG	20-20	.79"-.79"	71 (2.80")	52 (2.05")	20 (.79")	58 (2.28")	1,4 (.05")	30 (1.18")

ORDER EXAMPLE

C4 TG - 10-10 - PP

Code CTG (Material PP - PA - AU)

STANDARD SERIES
 PIPE CLAMPS
 DIN 3015, PART 1

C6 Q PROXIMITY SWITCHES RECTANGULAR TYPE

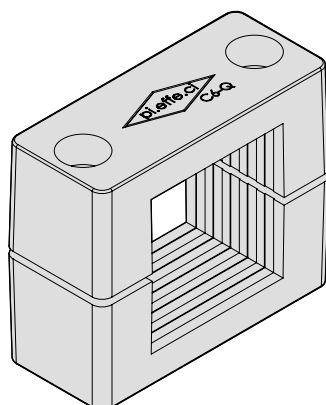
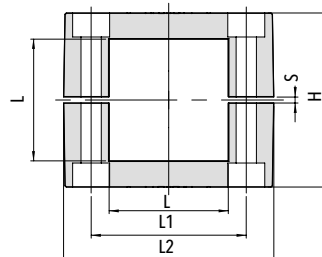

Code	L x L	L1	L2	H	S	Width
C6 Q	40 x 40 (1.57" x 1.57")	71 (2.8")	52 (2.05")	58 (2.28")	1,4 (.05")	30 (1.18")
	40 x 36 (1.57" x 1.42")					

ORDER EXAMPLE

C6 Q - 40x40 - PP

Code C6 Q (Material PP)





C7 C CLAMP BODY

CLAMPS WITH OVAL HOLE
FOR FIXING ELECTRIC CABLES

TWO CLAMP HALVES

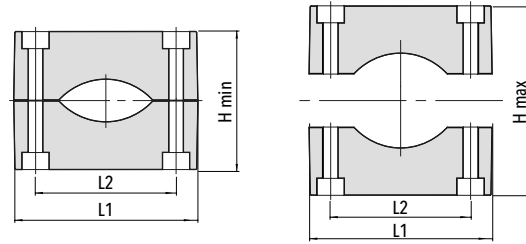
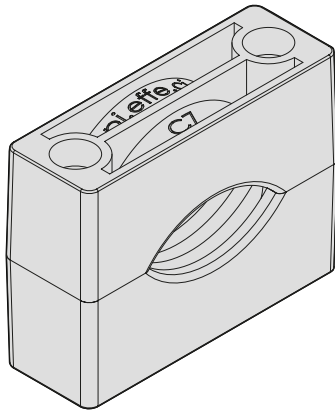

Code	Outside Diameter ØD	L1	L2	H min	H max	Width
C7 C	20 - 50 (.79" - 1.97")	86 (3.39")	66 (2.60")	64 (2.52")	94 (3.70")	30 (1.18")

ORDER EXAMPLE

C7 C - 20-50 - PP

Code C7 C (Material PP - PA - AU)



P SINGLE WELD PLATE

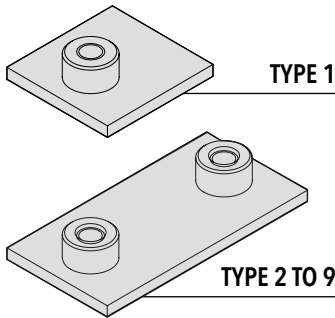
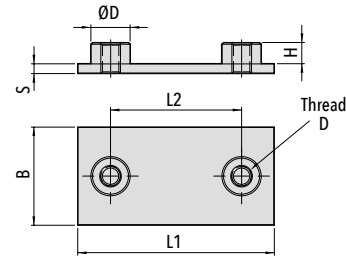
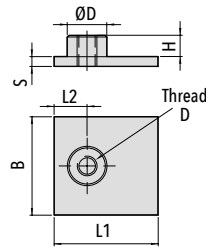

Code P (Carbon Steel S 235 JR)
Code XP (Stainless Steel AISI 316L).

Code	Thread D	L1	L2	B	S	H	ØD
P1 XP1	M6 (1/4-20 UNC)	31,5 (1.24")	10 (.39")	30 (1.18")	3 (.12")	6,5 (.26")	12 (.47")
P2 XP2	M6 (1/4-20 UNC)	36 (1.42")	20 (.79")	30 (1.18")	3 (.12")	6,5 (.26")	12 (.47")
P3 XP3	M6 (1/4-20 UNC)	42 (1.65")	26 (1.02")	30 (1.18")	3 (.12")	6,5 (.26")	12 (.47")
P4 XP4	M6 (1/4-20 UNC)	50 (1.97")	33 (1.30")	30 (1.18")	3 (.12")	6,5 (.26")	12 (.47")
P5 XP5	M6 (1/4-20 UNC)	60 (2.36")	40 (1.57")	30 (1.18")	3 (.12")	6,5 (.26")	12 (.47")
P6 XP6	M6 (1/4-20 UNC)	71 (2.80")	52 (2.05")	30 (1.18")	3 (.12")	6,5 (.26")	12 (.47")
P7 XP7	M6 (1/4-20 UNC)	88 (3.46")	66 (2.60")	30 (1.18")	3 (.12")	6,5 (.26")	12 (.47")
P8 XP8	M6 (1/4-20 UNC)	122 (4.80")	94 (3.70")	30 (1.18")	5 (.20")	6,5 (.26")	12 (.47")
P9 XP9	M6 (1/4-20 UNC)	148 (5.83")	120 (4.72")	30 (1.18")	5 (.20")	6,5 (.26")	12 (.47")

PL ELONGATED PLATE

(WITH SCREWS)

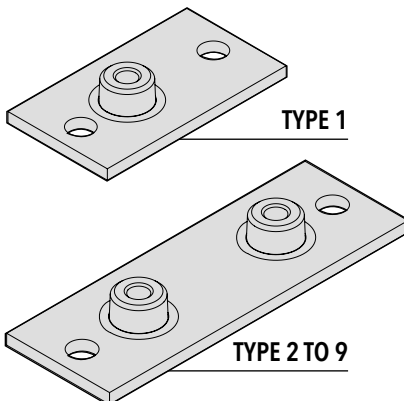
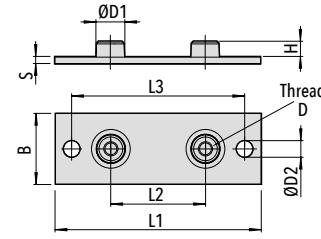
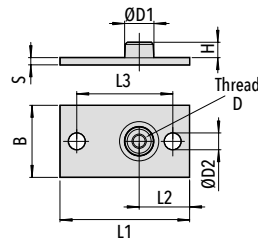

Code PL (Carbon Steel S 235 JR)
Code XPL (Stainless Steel AISI 316L)

Code	Thread D	L1	L2	L3	B	S	H	ØD1	ØD2
PL1 XPL1	M6 (1/4-20 UNC)	58 (2.28")	24,5 (.96")	44 (1.73")	30 (1.18")	3 (.12")	6,5 (.26")	12 (.47")	7 (.28")
PL2 XPL2	M6 (1/4-20 UNC)	64 (2.52")	20 (0.79")	50 (1.97")	30 (1.18")	3 (.12")	6,5 (.26")	12 (.47")	7 (.28")
PL3 XPL3	M6 (1/4-20 UNC)	70 (2.76")	26 (1.02")	56 (2.20")	30 (1.18")	3 (.12")	6,5 (.26")	12 (.47")	7 (.28")
PL4 XPL4	M6 (1/4-20 UNC)	78 (3.07")	33 (1.30")	64 (2.52")	30 (1.18")	3 (.12")	6,5 (.26")	12 (.47")	7 (.28")
PL5 XPL5	M6 (1/4-20 UNC)	87 (3.43")	40 (1.57")	73 (2.87")	30 (1.18")	3 (.12")	6,5 (.26")	12 (.47")	7 (.28")
PL6 XPL6	M6 (1/4-20 UNC)	100 (3.94")	52 (2.05")	86 (3.39")	30 (1.18")	3 (.12")	6,5 (.26")	12 (.47")	7 (.28")
PL7 XPL7	M6 (1/4-20 UNC)	115 (4.53")	66 (2.60")	100 (3.94")	30 (1.18")	3 (.12")	6,5 (.26")	12 (.47")	7 (.28")
PL8 XPL8	M6 (1/4-20 UNC)	150 (5.91")	94 (3.70")	136 (5.35")	30 (1.18")	5 (.20")	6,5 (.26")	12 (.47")	7 (.28")
PL9 XPL9	M6 (1/4-20 UNC)	178 (7.01")	120 (4.72")	162 (6.38")	30 (1.18")	5 (.20")	6,5 (.26")	12 (.47")	7 (.28")



PD TWIN WELD PLATE

FOR N. 2 CLAMPS

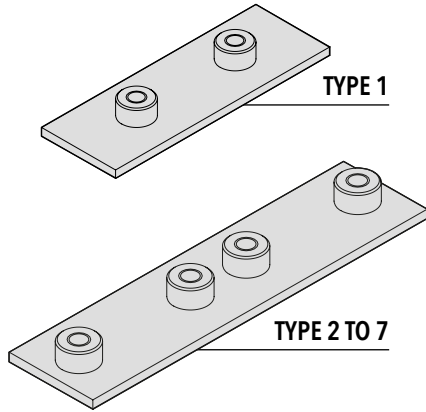

Code PD (Carbon Steel S 235 JR)
 Code XPD (Stainless Steel AISI 316L)

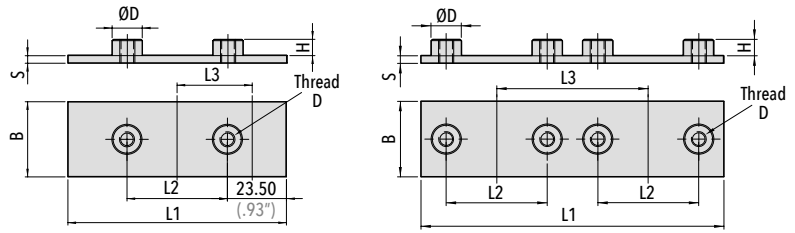

Code	Thread D	L1	L2	L3	B	S	H	ØD
PD1 XPD1	M6 (1/4-20 UNC)	87 (3.43")	40 (1.57")	40 (1.57")	30 (1.18")	3 (.12")	6,5 (.26")	12 (.47")
PD2 XPD2	M6 (1/4-20 UNC)	76 (3")	20 (.79")	38 (1.49")	30 (1.18")	3 (.12")	6,5 (.26")	12 (.47")
PD3 XPD3	M6 (1/4-20 UNC)	88 (3.46")	26 (1.02")	44 (1.73")	30 (1.18")	3 (.12")	6,5 (.26")	12 (.47")
PD4 XPD4	M6 (1/4-20 UNC)	102 (4.02")	33 (1.30")	51 (2")	30 (1.18")	3 (.12")	6,5 (.26")	12 (.47")
PD5 XPD5	M6 (1/4-20 UNC)	120 (4.72")	40 (1.57")	60 (2.36")	30 (1.18")	3 (.12")	6,5 (.26")	12 (.47")
PD6 XPD6	M6 (1/4-20 UNC)	150 (5.90")	52 (2.05")	75 (2.95")	30 (1.18")	3 (.12")	6,5 (.26")	12 (.47")
PD7 XPD7	M6 (1/4-20 UNC)	180 (7.08")	66 (2.60")	90 (3.54")	30 (1.18")	3 (.12")	6,5 (.26")	12 (.47")

22

PM MULTIPLE WELD PLATE

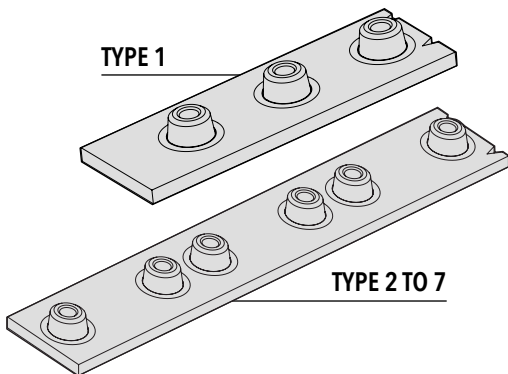

Code PM (Carbon Steel S 235 JR)
 Code XPM (Stainless Steel AISI 316L)

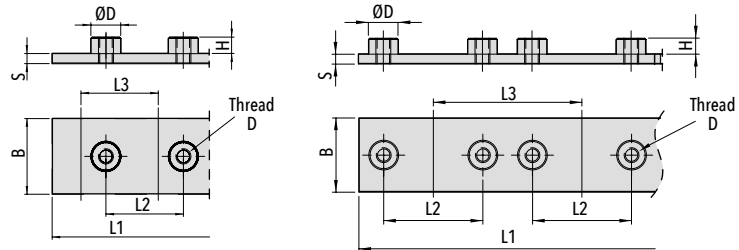

Code	Thread D	Nr. of Clamps	L1	L2	L3	B	S	H	ØD
PM1 XPM1	M6 (1/4-20 UNC)	10	310 (12.28")	31 (1.22")	31 (1.22")	30 (1.18")	4 (.16")	6,5 (.26")	12 (.47")
PM2 XPM2	M6 (1/4-20 UNC)	10	380 (14.96")	20 (.79")	38 (1.49")	30 (1.18")	4 (.16")	6,5 (.26")	12 (.47")
PM3 XPM3	M6 (1/4-20 UNC)	10	440 (17.32")	26 (1.02")	44 (1.73")	30 (1.18")	4 (.16")	6,5 (.26")	12 (.47")
PM4 XPM4	M6 (1/4-20 UNC)	10	520 (20.47")	33 (1.30")	52 (2.05")	30 (1.18")	4 (.16")	6,5 (.26")	12 (.47")
PM5 XPM5	M6 (1/4-20 UNC)	5	300 (11.81")	40 (1.57")	60 (2.36")	30 (1.18")	4 (.16")	6,5 (.26")	12 (.47")
PM6 XPM6	M6 (1/4-20 UNC)	5	375 (14.76")	52 (2.05")	75 (2.95")	30 (1.18")	4 (.16")	6,5 (.26")	12 (.47")
PM7 XPM7	M6 (1/4-20 UNC)	5	450 (17.72")	66 (2.60")	90 (3.54")	30 (1.18")	4 (.16")	6,5 (.26")	12 (.47")

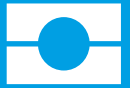

PM C 1P

SINGLE SPACED PLATE

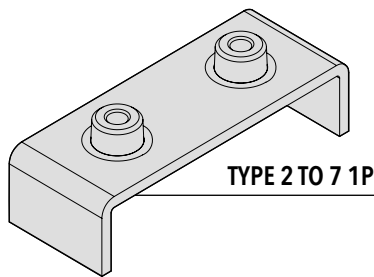
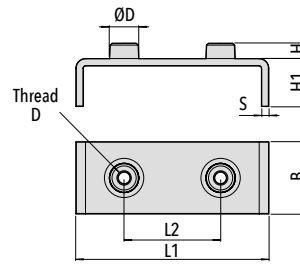

Code **PM C 1P** Carbon Steel S 235 JR
Code **XPM C 1P** (Stainless Steel AISI 316L)

Code	Thread D	L1	L2	H	H1	B	S	ØD
PM C2 1P XPM C2 1P	M6 (1/4-20 UNC)	60 (2.36")	20 (.79")	6,5 (.26")	20 (.79")	30 (1.18")	3 (.12")	12 (.47")
PM C3 1P XPM C3 1P	M6 (1/4-20 UNC)	66 (2.60")	26 (1.02")	6,5 (.26")	20 (.79")	30 (1.18")	3 (.12")	12 (.47")
PM C4 1P XPM C4 1P	M6 (1/4-20 UNC)	73 (2.87")	33 (1.30")	6,5 (.26")	20 (.79")	30 (1.18")	3 (.12")	12 (.47")
PM C5 1P XPM C5 1P	M6 (1/4-20 UNC)	80 (3.15")	40 (1.57")	6,5 (.26")	20 (.79")	30 (1.18")	3 (.12")	12 (.47")
PM C6 1P XPM C6 1P	M6 (1/4-20 UNC)	92 (3.62")	52 (2.05")	6,5 (.26")	20 (.79")	30 (1.18")	3 (.12")	12 (.47")
PM C7 1P XPM C7 1P	M6 (1/4-20 UNC)	100 (3.94")	66 (2.60")	6,5 (.26")	20 (.79")	30 (1.18")	3 (.12")	12 (.47")

PM C 2P

MULTIPLE SPACED PLATE

FOR N.2 CLAMPS

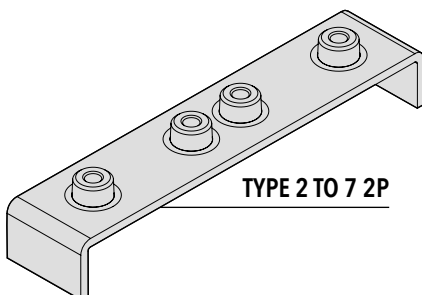
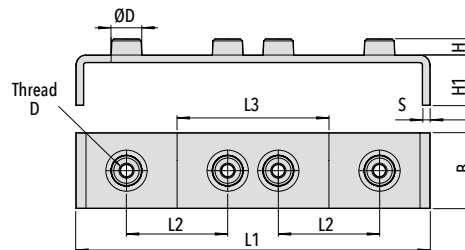

Code **PM C 2P** Carbon Steel S 235 JR
Code **XPM C 2P** (Stainless Steel AISI 316L)

Code	Thread D	L1	L2	L3	H	H1	B	S	ØD
PM C2 2P XPM C2 2P	M6 (1/4-20 UNC)	98 (3.86")	20 (.79")	38 (1.50")	6,5 (.26")	20 (.79")	30 (1.18")	3 (.12")	12 (.47")
PM C3 2P XPM C3 2P	M6 (1/4-20 UNC)	110 (4.33")	26 (1.02")	44 (1.73")	6,5 (.26")	20 (.79")	30 (1.18")	3 (.12")	12 (.47")
PM C4 2P XPM C4 2P	M6 (1/4-20 UNC)	124 (4.88")	33 (1.30")	51 (2")	6,5 (.26")	20 (.79")	30 (1.18")	3 (.12")	12 (.47")
PM C5 2P XPM C5 2P	M6 (1/4-20 UNC)	140 (5.51")	40 (1.57")	60 (2.36")	6,5 (.26")	20 (.79")	30 (1.18")	3 (.12")	12 (.47")
PM C6 2P XPM C6 2P	M6 (1/4-20 UNC)	166 (6.53")	52 (2.05")	75 (2.95")	6,5 (.26")	20 (.79")	30 (1.18")	3 (.12")	12 (.47")
PM C7 2P XPM C7 2P	M6 (1/4-20 UNC)	195 (7.68")	66 (2.60")	90 (3.54")	6,5 (.26")	20 (.79")	30 (1.18")	3 (.12")	12 (.47")



PM C 4P MULTIPLE SPACED PLATE

FOR N.4 CLAMPS

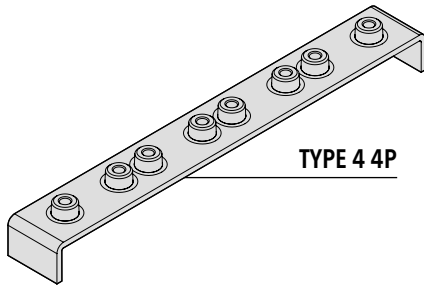
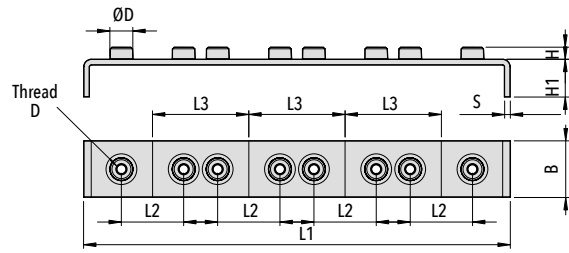

TYPE 4 4P

Code	Thread D	L1	L2	L3	H	H1	B	S	ØD
PM C4 4P XPM C4 4P	M6 (1/4-20 UNC)	226 (8.90")	33 (1.30")	51 (2")	6,5 (.26")	20 (.79")	30 (1.18")	3 (.12")	12 (.47")

Code **PM C 4P** Carbon Steel S 235 JR)
 Code **XPM C 4P** (Stainless Steel AISI 316L)



PS UPPER PLATE

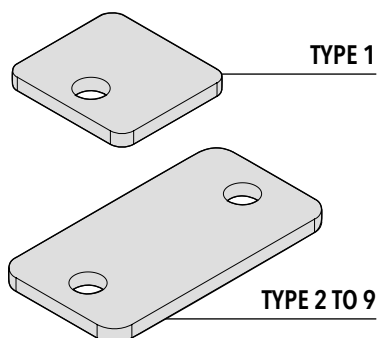
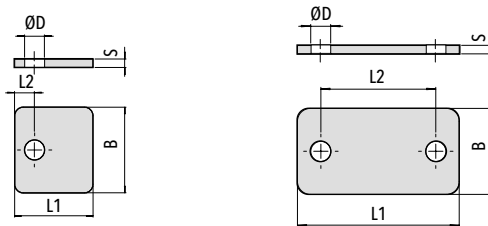

Code PS (Carbon Steel S 235 JR)
Code XPS (Stainless Steel AISI 316L)

Code	L1	L2	B	S	ØD
PS1 XPS1	28 (1.10")	9 (.35")	30 (1.18")	3 (.12")	7 (.28")
PS2 XPS2	34,5 (1.36")	20 (.79")	30 (1.18")	3 (.12")	7 (.28")
PS3 XPS3	40,5 (1.59")	26 (1.02")	30 (1.18")	3 (.12")	7 (.28")
PS4 XPS4	48 (1.89")	33 (1.30")	30 (1.18")	3 (.12")	7 (.28")
PS5 XPS5	56,5 (2.22")	40 (1.57")	30 (1.18")	3 (.12")	7 (.28")
PS6 XPS6	69,5 (2.74")	52 (2.05")	30 (1.18")	3 (.12")	7 (.28")
PS7 XPS7	85,5 (3.36")	66 (2.60")	30 (1.18")	3 (.12")	7 (.28")
PS8 XPS8	118 (4.65")	94 (3.70")	30 (1.18")	5 (.20")	7 (.28")
PS9 XPS9	144 (5.67")	120 (4.72")	30 (1.18")	5 (.20")	7 (.28")

DIN 3015, PART 1
 PIPE CLAMPS
STANDARD SERIES

VE HEXAGON HEAD BOLT

ISO 4014 / 4017
FOR USE WITH UPPER PLATE PS

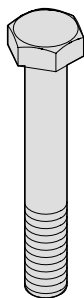

Code VE (Steel 8.8)
Code XVE (Stainless Steel A4)

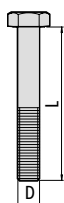

Code	Thread (D x L)
VE1 XVE1	M6x30 (1/4-20 UNCx1.1/4")
VE2 XVE2	M6x30 (1/4-20 UNCx1.1/4")
VE3 XVE3	M6x35 (1/4-20 UNCx1.3/8")
VE4 XVE4	M6x40 (1/4-20 UNCx1.1/2")
VE5 XVE5	M6x45 (1/4-20 UNCx1.7/8")
VE6 XVE6	M6x60 (1/4-20 UNCx2.3/8")
VE7 XVE7	M6x70 (1/4-20 UNCx2.3/4")
VE8 XVE8	M6x100 (1/4-20 UNCx4")
VE9 XVE9	M6x125 (1/4-20 UNCx4.7/8")

TCEI SOCKET CAP SCREW

ISO 4762

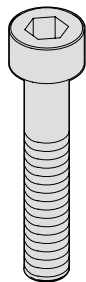

Code TCEI (Steel 8.8)
Code XTCEI (Stainless Steel AISI 316L)

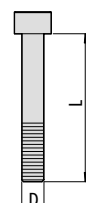

Code	Thread (D x L)
TCEI1 XTCEI1	M6x20 (1/4-20 UNCx3/4")
TCEI2 XTCEI2	M6x20 (1/4-20 UNCx3/4")
TCEI3 XTCEI3	M6x25 (1/4-20 UNCx1")
TCEI4 XTCEI4	M6x30 (1/4-20 UNCx1.1/8")
TCEI5 XTCEI5	M6x35 (1/4-20 UNCx1.3/8")
TCEI6 XTCEI6	M6x50 (1/4-20 UNCx2")
TCEI7 XTCEI7	M6x60 (1/4-20 UNCx2.1/2")
TCEI8 XTCEI8	M6x90 (1/4-20 UNCx3.3/8")
TCEI9 XTCEI9	M6x110 (1/4-20 UNCx4.3/8")



B BUSHING

FOR USE WITH HEXAGON HEAD BOLT **VEB**
 (NO UPPER PLATE)

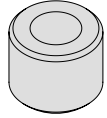
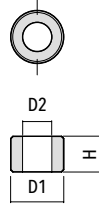

FOR CLAMPS **C1 TO C7**
 AND **AC1 TO AC7**

Code	D1	D2	H
B XB	11,5 (.45")	6,5 (.26")	8 (.31")

Code B (Carbon Steel S 235 JR) - **Code XB** (Stainless Steel AISI 316L)

RP FLAT WASHER

FOR USE WITH SCREW **TCEI / VA**

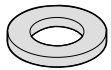
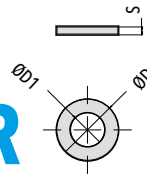

FOR CLAMPS **C1 TO C9**
 AND **AC1 TO AC7**

Code	ØD	ØD1	S
RP XRP	11,5 (.45")	6,3 (.25")	0,8 (.03")

Code RP (Carbon Steel S 235 JR) - **Code XRP** (Stainless Steel AISI 316L)

VEB HEXAGON HEAD BOLT

FOR USE WITH BUSHING **B**

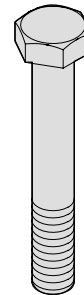
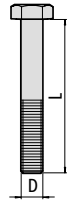

Code VEB (Steel 8.8)

Code XVEB (Stainless Steel A4)

Code	Thread (D x L)
VEB1 XVEB1	M6x27 (1/4-20 UNCx1.1/8")
VEB2 XVEB2	M6x27 (1/4-20 UNCx1.1/8")
VEB3 XVEB3	M6x32 (1/4-20 UNCx1.3/8")
VEB4 XVEB4	M6x35 (1/4-20 UNCx1.3/8")
VEB5 XVEB5	M6x42 (1/4-20 UNCx1.5/8")
VEB6 XVEB6	M6x57 (1/4-20 UNCx2.3/8")
VEB7 XVEB7	M6x65 (1/4-20 UNCx2.3/4")

26

RS / RSL SAFETY WASHER

FOR USE WITH HEXAGON HEAD BOLT
VE / VEB

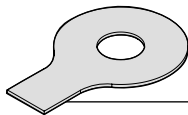

RS/XRS
DIN 93

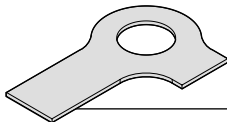

RSL/XRSL
DIN 463

FOR CLAMPS **C1 TO C9**
 AND **AC1 TO AC7**

Code RS 6,4 DIN 93 (Carbon Steel S 235 JR)

Code XRS 6,4 DIN 93 (Stainless Steel A4)

Code RSL 6,4 DIN 463 (Carbon Steel S 235 JR)

Code XRSL 6,4 DIN 463 (Stainless Steel A4)

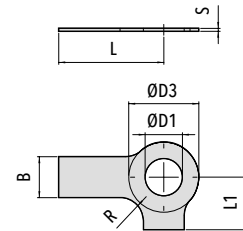
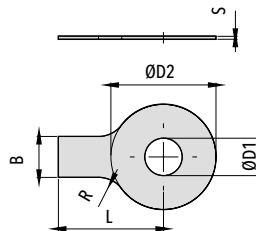

Code	ØD1	B	ØD2	ØD3	L	L1	R	S
RS XRS	6,4 (.25")	7 (.28")	19 (.75")	12 (.47")	18 (.71")	9 (.35")	4 (.16")	0,5 (.02")
RSL XRSL								



VA HIGH HEXAGON HEAD BOLT

FOR STACKED CLAMPS

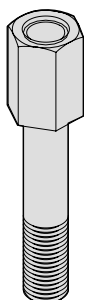

Code VA (Carbon Steel S 235 JR)
Code XVA (Stainless Steel AISI 316L)

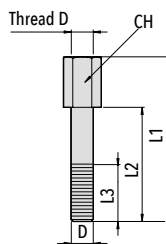

Code	Thread D	L1	L2	L3	CH
VA1 XVA1	M6 (1/4-20 UNC)	34 (1.34")	20 (.79")	14 (.55")	11 (.43")
VA2 XVA2	M6 (1/4-20 UNC)	34 (1.34")	20 (.79")	14 (.55")	11 (.43")
VA3 XVA3	M6 (1/4-20 UNC)	39 (1.53")	25 (.98")	14 (.55")	11 (.43")
VA4 XVA4	M6 (1/4-20 UNC)	43 (1.70")	29 (1.14")	14 (.55")	11 (.43")
VA5 XVA5	M6 (1/4-20 UNC)	49 (1.93")	35 (1.38")	14 (.55")	11 (.43")
VA6 XVA6	M6 (1/4-20 UNC)	64 (2.52")	50 (1.97")	14 (.55")	11 (.43")
VA7 XVA7	M6 (1/4-20 UNC)	73 (2.87")	59 (2.32")	14 (.55")	11 (.43")
VA8 XVA8	M6 (1/4-20 UNC)	99 (3.90")	85 (3.35")	14 (.55")	11 (.43")
VA9 XVA9	M6 (1/4-20 UNC)	124 (4.88")	110 (4.33")	14 (.55")	11 (.43")

STANDARD SERIES
 PIPE CLAMPS
 DIN 3015, PART 1

PB LOCKING PLATE

FOR STACKED CLAMPS

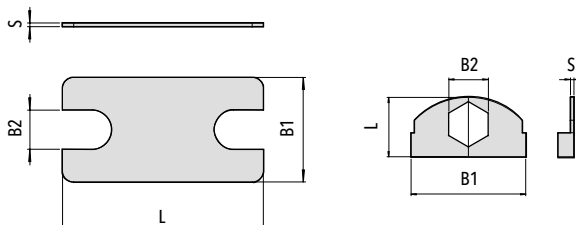
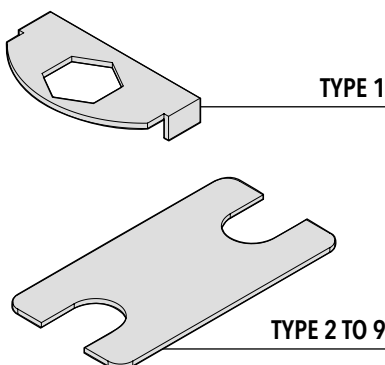

Code	L	B1	B2	S
PB1 XPB1	17 (.67")	32 (1.26")	11,2 (.44")	1 (.04")
PB2 XPB2	33 (1.30")	28 (1.10")	11,2 (.44")	1 (.04")
PB3 XPB3	39 (1.54")	28 (1.10")	11,2 (.44")	1 (.04")
PB4 XPB4	47 (1.85")	28 (1.10")	11,2 (.44")	1 (.04")
PB5 XPB5	54 (2.12")	28 (1.10")	11,2 (.44")	1 (.04")
PB6 XPB6	66 (2.60")	28 (1.10")	11,2 (.44")	1 (.04")
PB7 XPB7	80,3 (3.16")	28 (1.10")	11,2 (.44")	1 (.04")
PB8 XPB8	117 (4.61")	28 (1.10")	11,2 (.44")	1 (.04")
PB9 XPB9	143 (5.63")	28 (1.10")	11,2 (.44")	1 (.04")

Code PB (Carbon Steel S 235 JR)
Code XPB (Stainless Steel AISI 316L)



BB MOUNTING RAIL

AVAILABLE HEIGHTS 11 / 14 / 30 mm
 AVAILABLE LENGTH 2 m

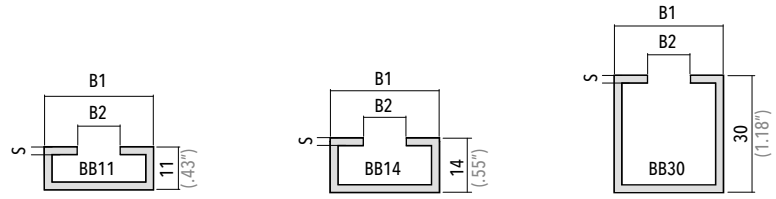
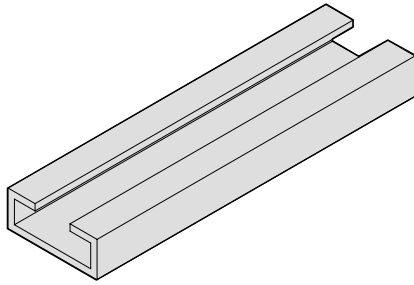

Code	B1	B2	S
BB XBB	28 (1.10")	11 (.43")	2 (.08")

Code **BB** (Steel DX51D)
 Code **XBB** (Stainless Steel AISI 316L)

28

DF+AG / DF-C RAIL NUT WITH RUBBER RING

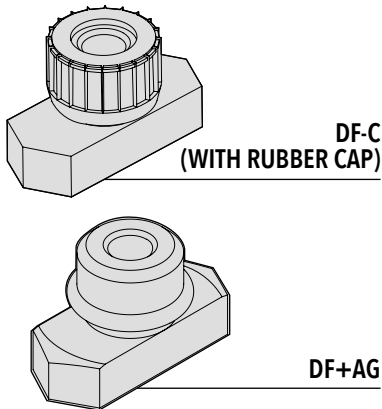
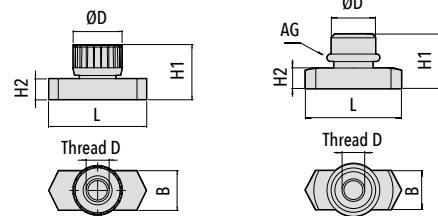

Code	Thread D	L	B	H1	H2	ØD	AG
DF/DF-C XDF	M6 (1/4-20 UNC)	25,5 (1")	10,4 (.41")	14,5 (.57")	5,5 (.22")	11,8 (.46")	10x2,2 (.39"x.08")

Code **DF / DF-C** (Steel C20)
 Code **XDF** (Stainless Steel AISI 316L)



BB P MOUNTING HEAVY RAIL

AVAILABLE LENGTHS 1 m / 2 m

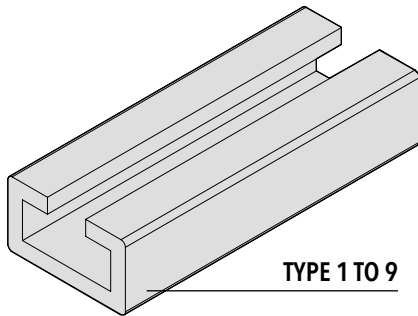
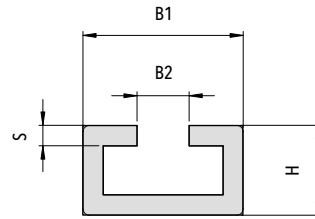

Code	B1	B2	H	S
BB P XBB P	40 (1.57")	13 (.51")	22 (.86")	5 (.19")

Code **BB P** (Carbon Steel S 235 JR)
Code **XBB P** (Stainless Steel AISI 316L)

STANDARD SERIES
 PIPE CLAMPS
 DIN 3015, PART 1

DF PS+AG RAIL NUT WITH RUBBER RING

FOR MOUNTING HEAVY RAIL

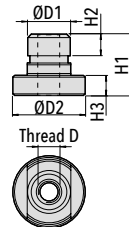

29

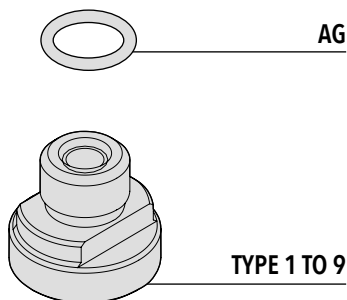

Code	ØD1	ØD2	H1	H2	H3	Thread D	AG
DF PS XDF PS + AG	11,8 (.46")	20 (.79")	17 (.67")	6 (.24")	5,6 (.22")	M6 (1/4-20 UNC)	10x2,2 (.39"x.08")

Code **DF PS** (Carbon Steel S 235 JR)
Code **XDF PS** (Stainless Steel AISI 316L)



MOUNTING EXAMPLE 01

Complete clamp C1 type in Polypropylene for pipe with outside diameter of 12 mm with single weld plate.

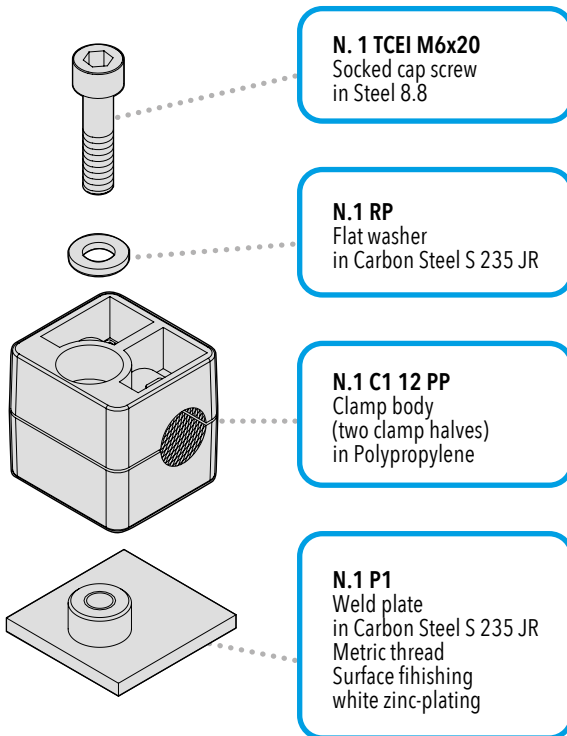

MOUNTING EXAMPLE 02

Complete Aluminium clamp AC1 type for pipe with outside diameter of 12 mm with elongated plate with fixing holes and upper plate.

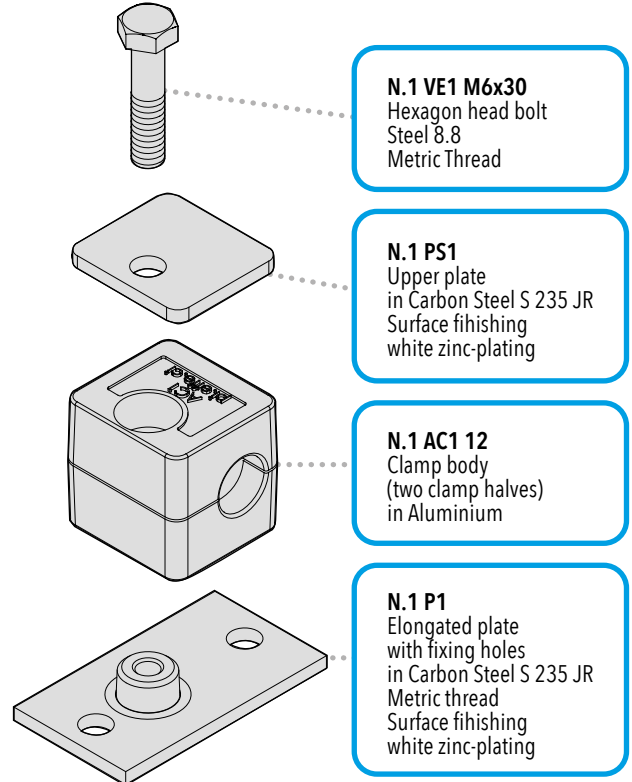

30

MOUNTING EXAMPLE 03

Complete clamp C1 type side by side in Polypropylene for pipe with outside diameter of 12 mm, with double weld plate and upper plate.

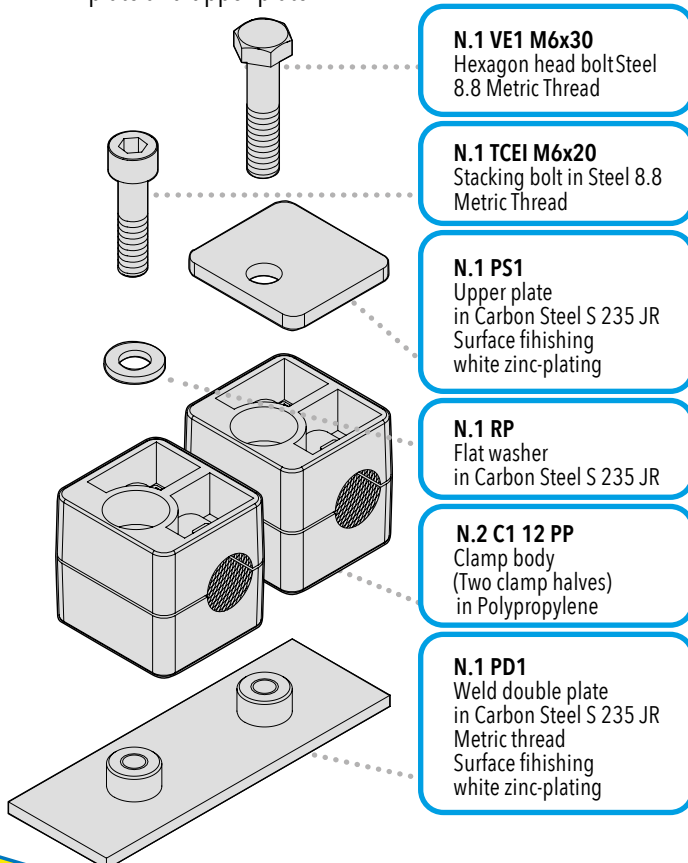

MOUNTING EXAMPLE 04

Complete clamp C5 in Polypropylene for pipe with outside diameter of 30 mm, with single weld plate.

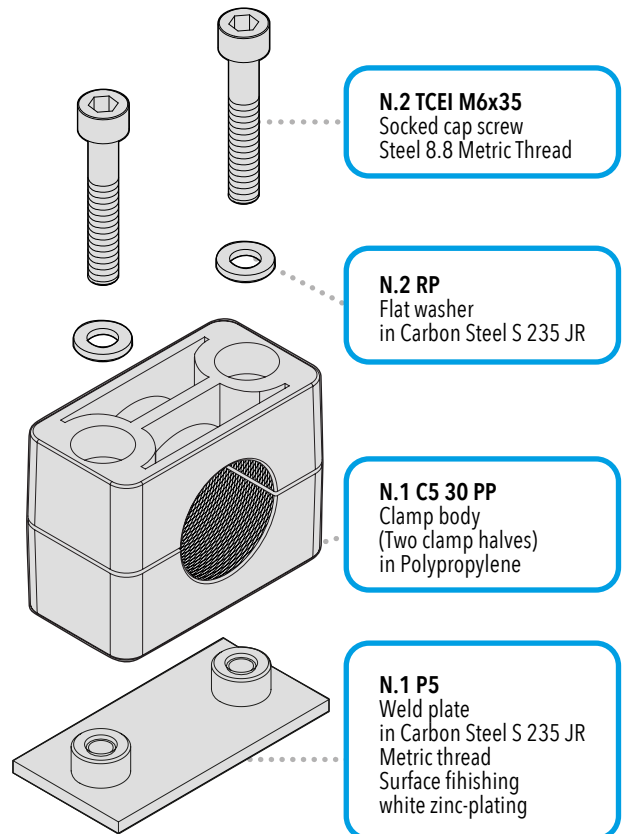



MOUNTING EXAMPLE 05

Complete stacked clamp C1 in Rubber for pipe with outside diameter of 12 mm, elongated plate with fixing holes and upper plate.

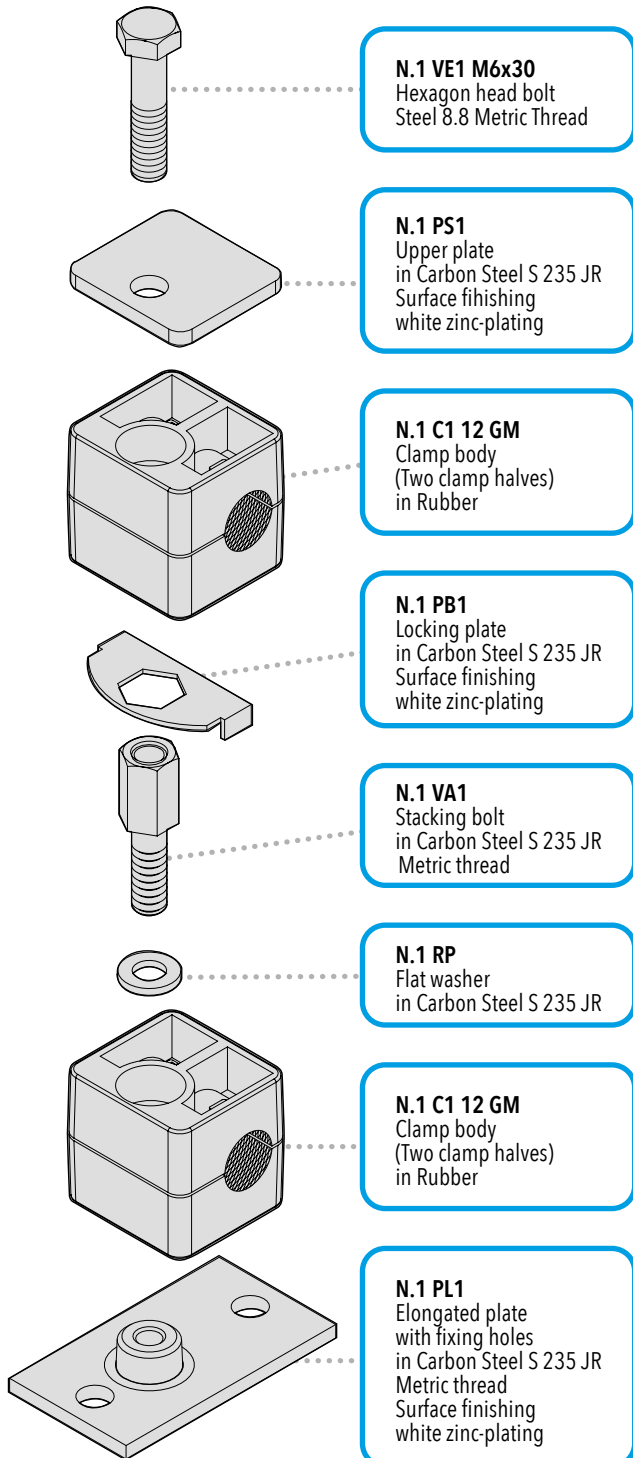

MOUNTING EXAMPLE 06

Complete stacked clamp C5 in Polypropylene for pipe with outside diameter of 30mm single weld plate and upper plate.

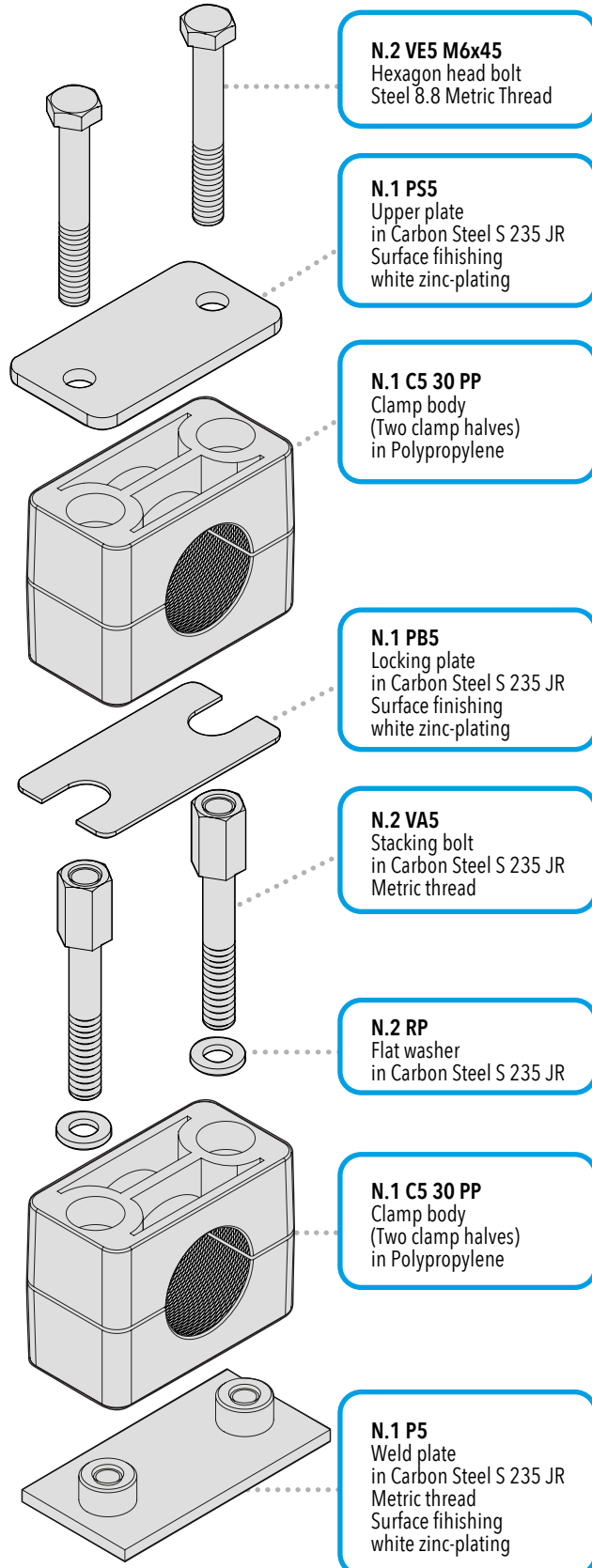

**MOUNTING EXAMPLE 07**

Mounting Example of complete clamp C5 in Polypropylene for pipe with outside diameter of 30 mm, elongated plate with fixing holes and upper plate.

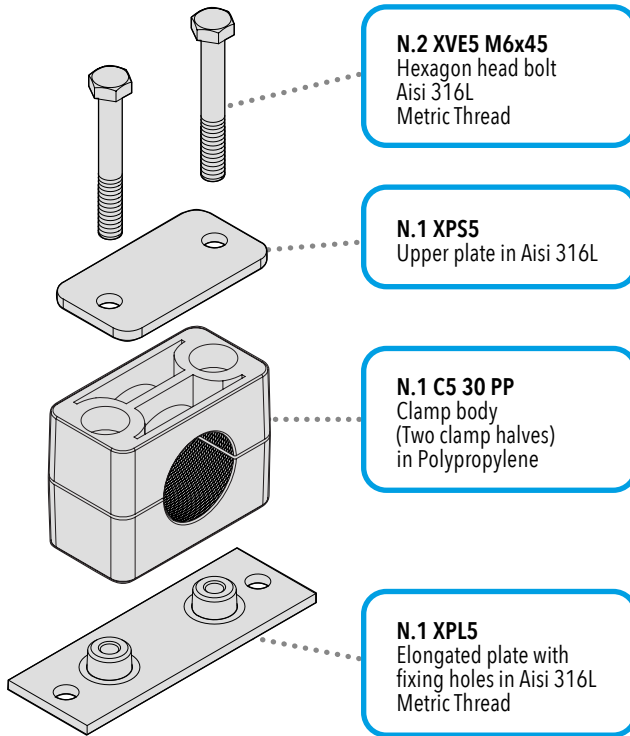
**MOUNTING EXAMPLE 08**

Mounting Example of complete clamp C5 in Aluminium for pipe with outside diameter of 30 mm, elongated plate with fixing holes and upper plate.

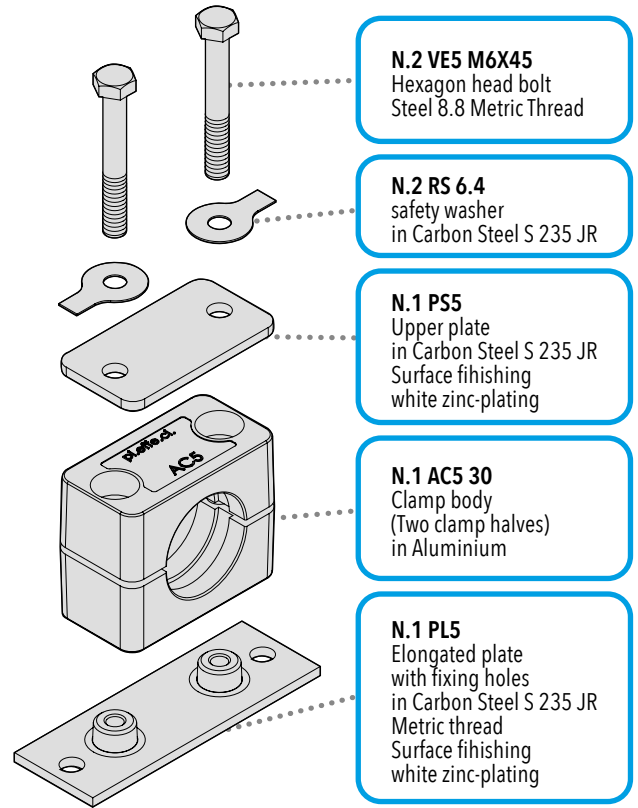

32

MOUNTING EXAMPLE 09

Mounting Example of complete clamp C5 type side by side in Polypropylene for pipe with outside diameter of 30 mm, with double weld plate.

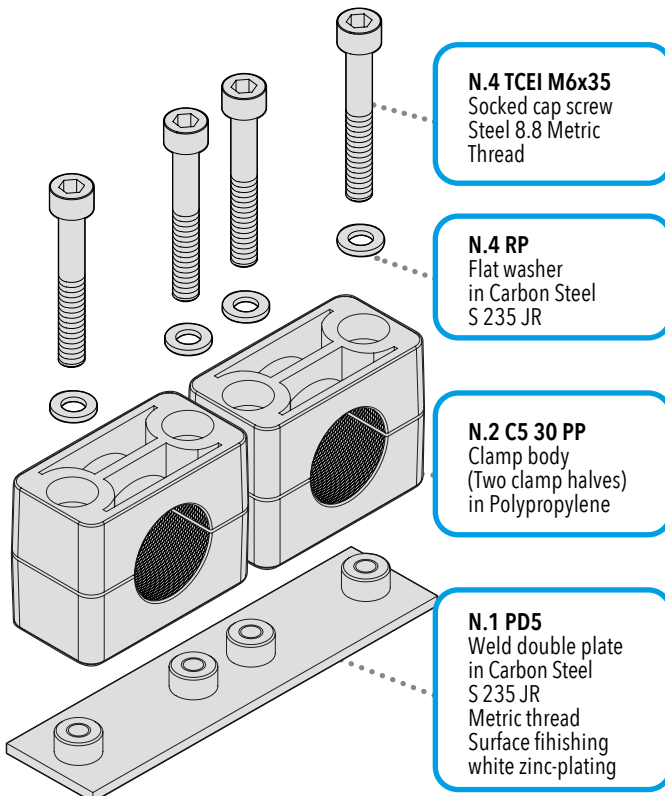
**MOUNTING EXAMPLE 10**

Mounting Example of complete clamp C5 in Rubber for pipe with outside diameter of 30mm, with single weld plate with bushing.

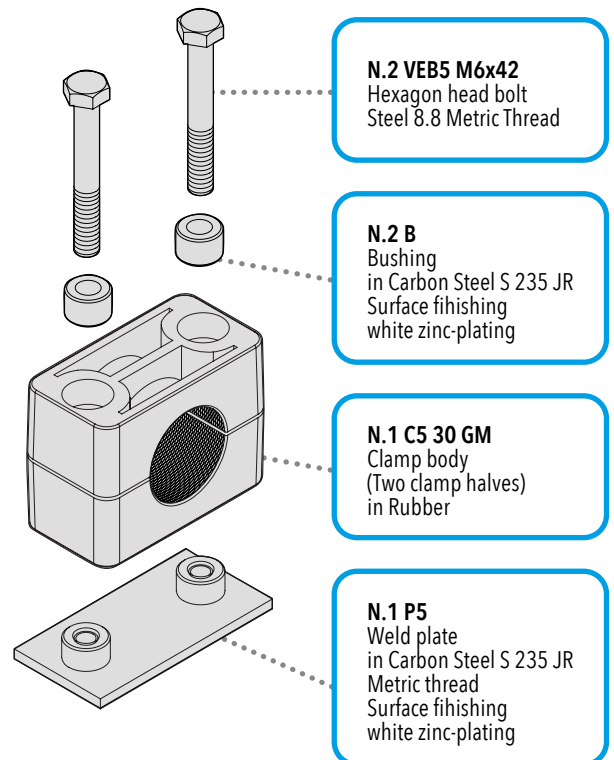



MOUNTING EXAMPLE 11

Mounting Example of complete clamp C5 in Polypropylene for pipe with outside diameter of 30 mm, mounting rail nut.

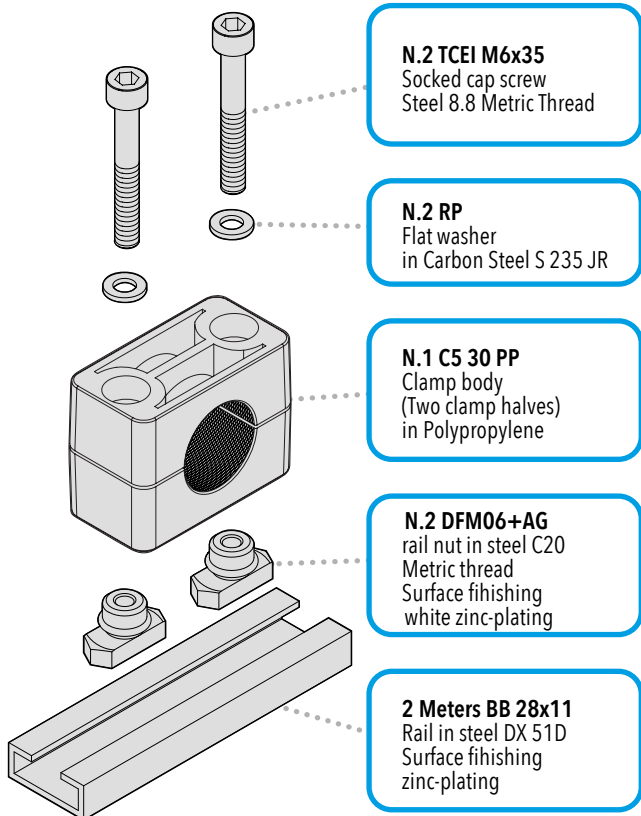

N.2 TCEI M6x35
Socked cap screw
Steel 8.8 Metric Thread

N.2 RP
Flat washer
in Carbon Steel S 235 JR

N.1 C5 30 PP
Clamp body
(Two clamp halves)
in Polypropylene

N.2 DFM06+AG
rail nut in steel C20
Metric thread
Surface finishing
white zinc-plating

2 Meters BB 28x11
Rail in steel DX 51D
Surface finishing
zinc-plating

MOUNTING EXAMPLE 12

Proximity switches Rectangular type. Mounting clamp type C6Q and accessories standard series. We recommend the use of the rail for the axial and horizontal position adjustment.

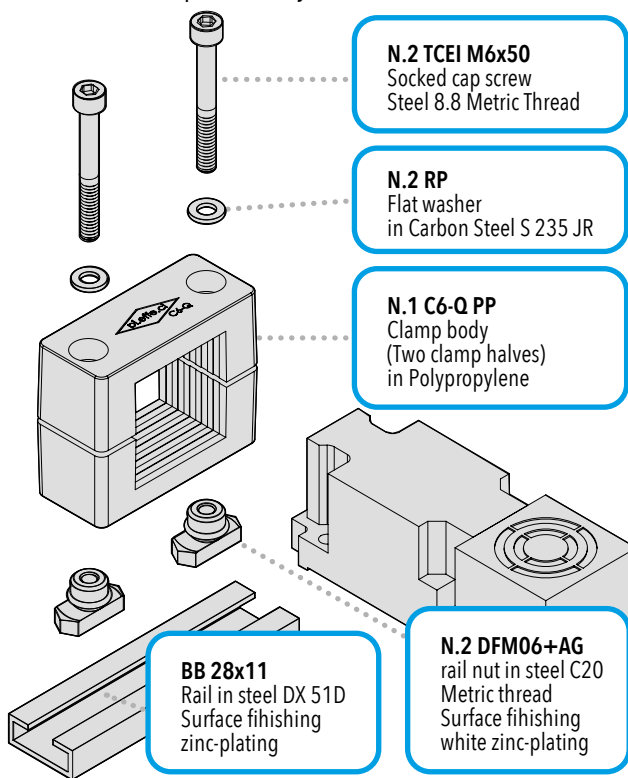

N.2 TCEI M6x50
Socked cap screw
Steel 8.8 Metric Thread

N.2 RP
Flat washer
in Carbon Steel S 235 JR

N.1 C6-Q PP
Clamp body
(Two clamp halves)
in Polypropylene

BB 28x11
Rail in steel DX 51D
Surface finishing
zinc-plating

N.2 DFM06+AG
rail nut in steel C20
Metric thread
Surface finishing
white zinc-plating

MOUNTING EXAMPLE 13

Clamps with oval hole for fixing electric cables. Clamp type C7 for the standard series for cable diameters between 20 and 50 mm.

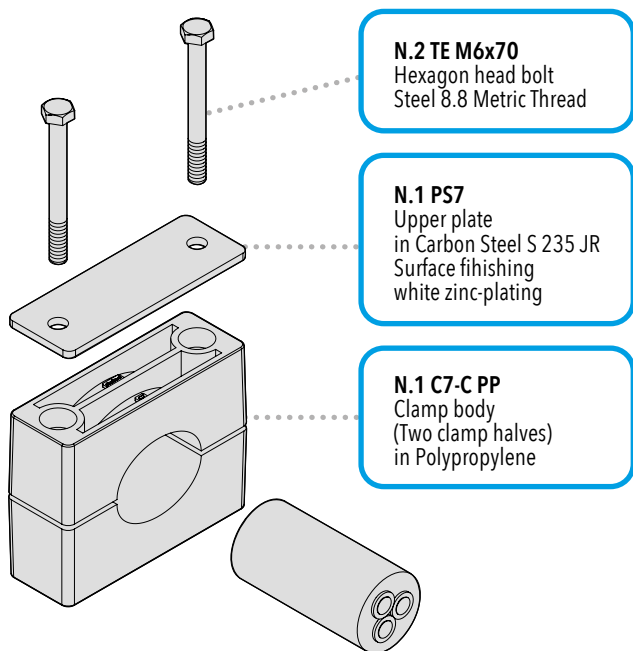

N.2 TE M6x70
Hexagon head bolt
Steel 8.8 Metric Thread

N.1 PS7
Upper plate
in Carbon Steel S 235 JR
Surface finishing
white zinc-plating

N.1 C7-C PP
Clamp body
(Two clamp halves)
in Polypropylene

MOUNTING EXAMPLE 14

Mounting Example of complete clamp C5 in Polypropylene for pipe with outside diameter of 30 mm, with single spaced plate 1 position.

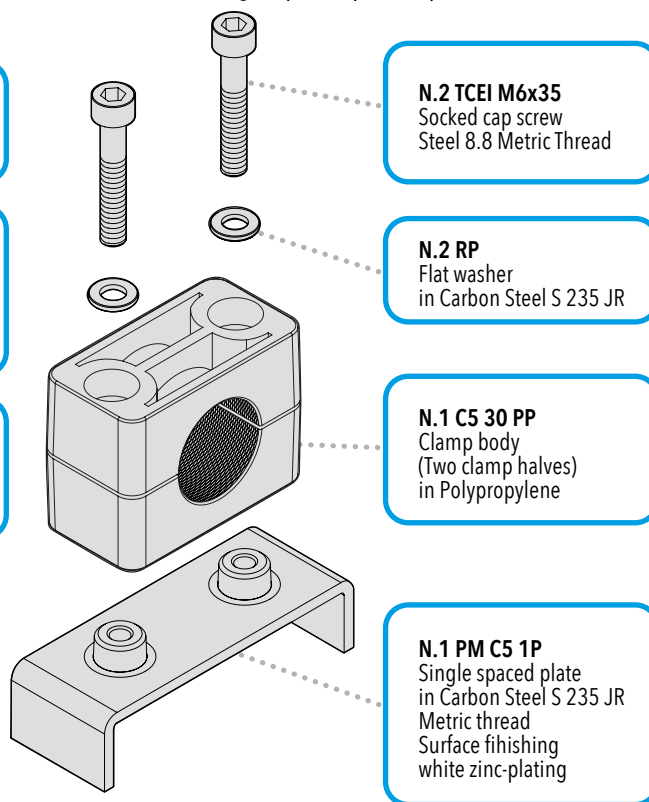

N.2 TCEI M6x35
Socked cap screw
Steel 8.8 Metric Thread

N.2 RP
Flat washer
in Carbon Steel S 235 JR

N.1 C5 30 PP
Clamp body
(Two clamp halves)
in Polypropylene

N.1 PM C5 1P
Single spaced plate
in Carbon Steel S 235 JR
Metric thread
Surface finishing
white zinc-plating



MOUNTING EXAMPLE 15

Mounting Example of complete clamp C5 in Polypropylene for pipe with outside diameter of 30 mm, with multiple spaced plate 2 positions.

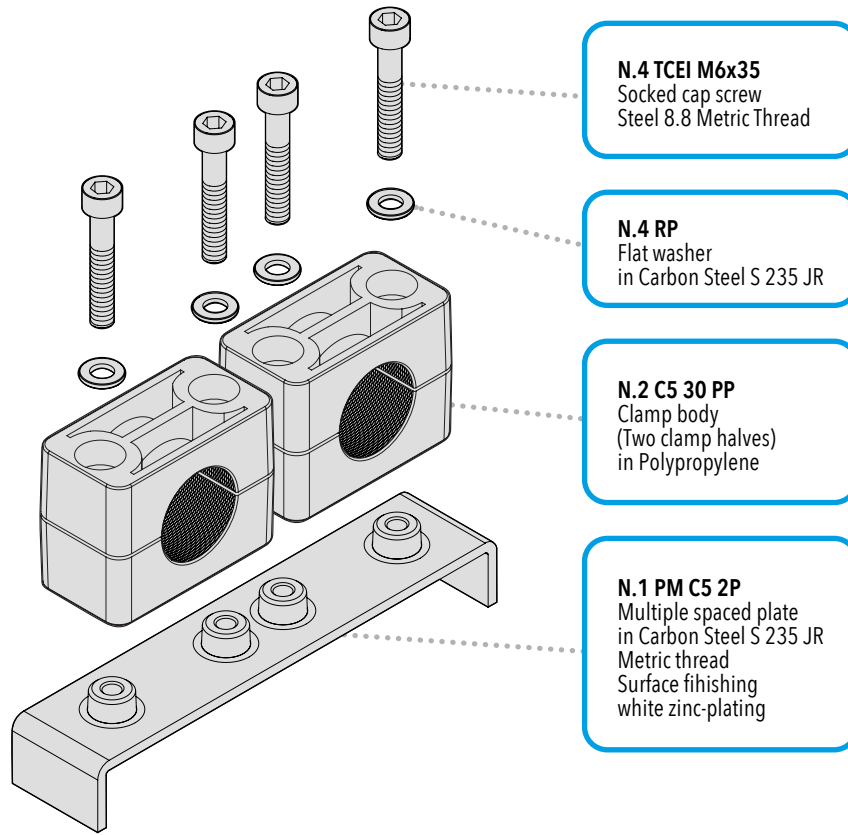

MOUNTING EXAMPLE 16

Mounting Example of complete clamp C5 in Polypropylene for pipe with outside diameter of 30 mm, with multiple spaced plate 4 positions and upper plate.

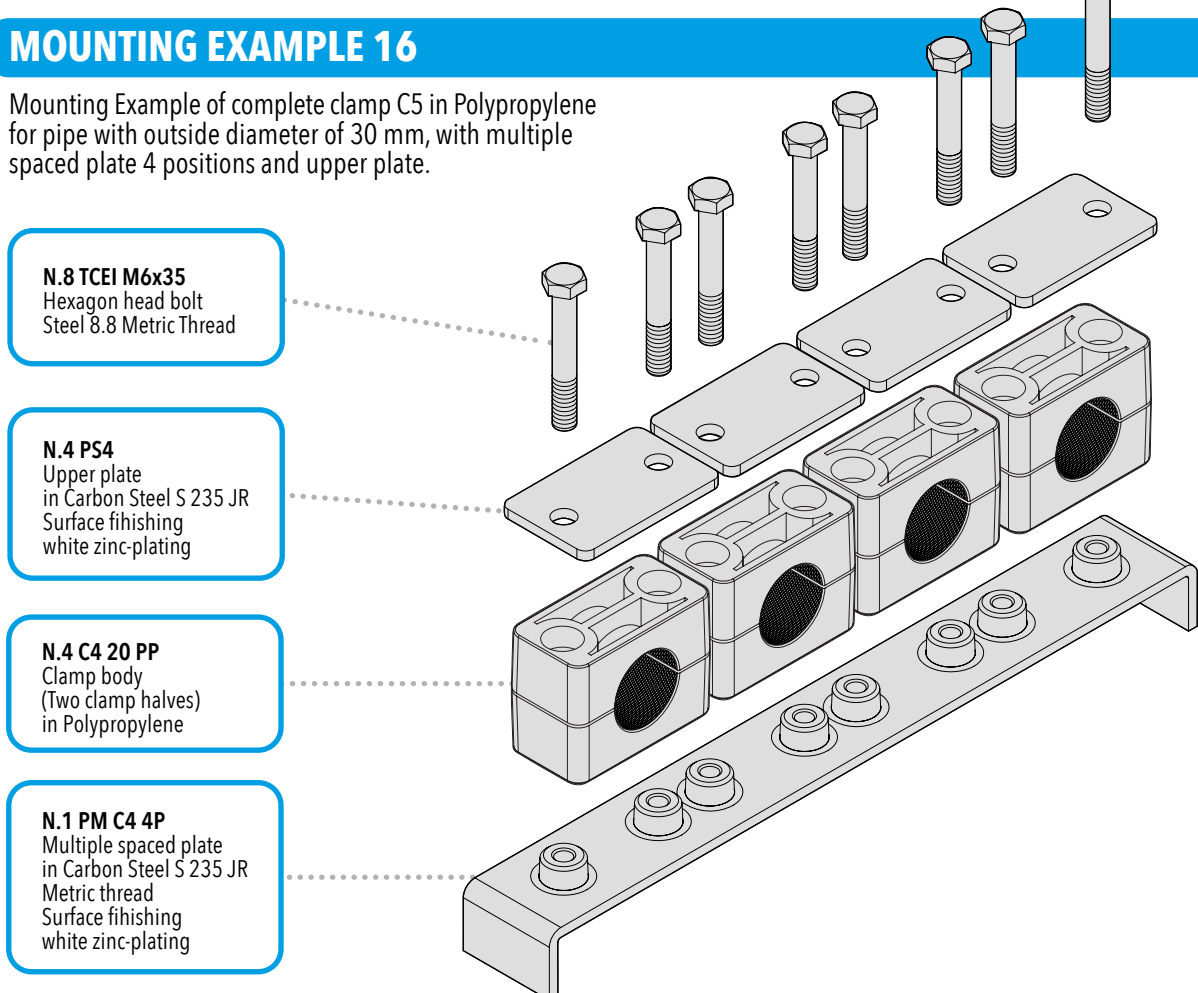



MOUNTING EXAMPLE 17

Mounting Example of complete clamp C5 in Polypropylene for pipe with outside diameter of 30 mm, mounting special rail nut.

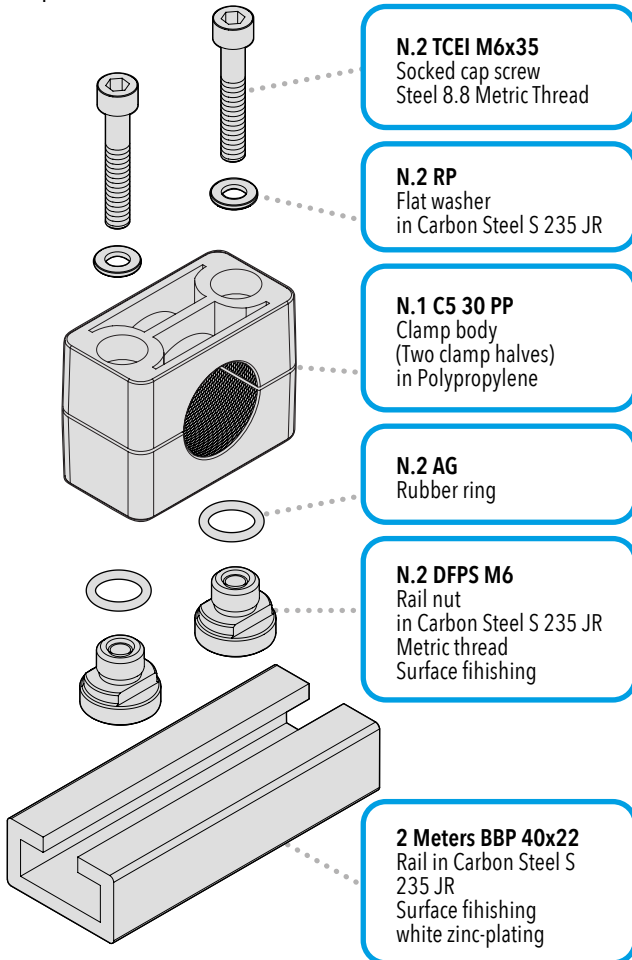

MOUNTING EXAMPLE 18

Mounting Example of complete clamp CB5 in Polypropylene with rubber bushing for pipe with outside diameter of 30 mm, single weld plate..

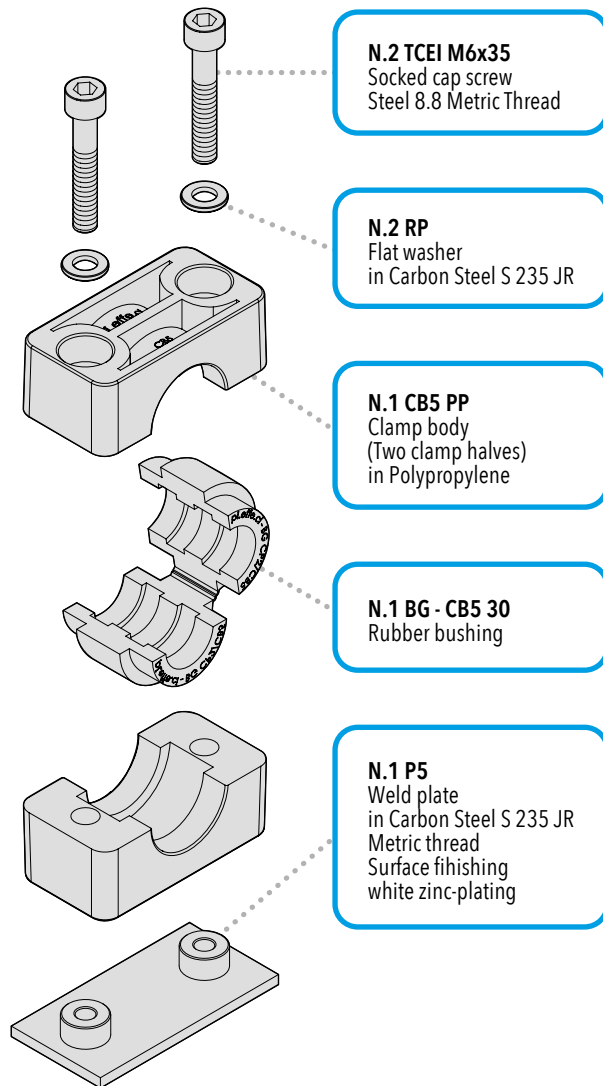



MOUNTING EXAMPLE 19

Mounting Example of complete clamp CB5 in Polypropylene with rubber bushing for pipe with outside diameter of 30 mm, single weld plate and upper plate

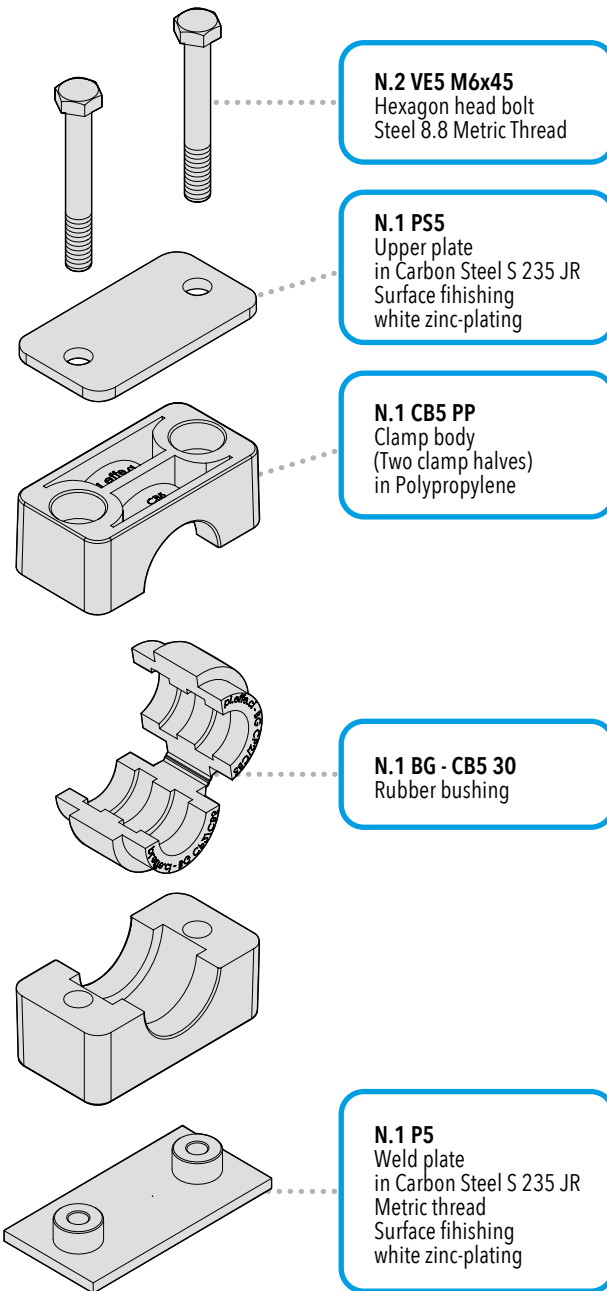

N.2 VE5 M6x45
 Hexagon head bolt
 Steel 8.8 Metric Thread

N.1 PS5
 Upper plate
 in Carbon Steel S 235 JR
 Surface finishing
 white zinc-plating

N.1 CB5 PP
 Clamp body
 (Two clamp halves)
 in Polypropylene

N.1 BG - CB5 30
 Rubber bushing

N.1 P5
 Weld plate
 in Carbon Steel S 235 JR
 Metric thread
 Surface finishing
 white zinc-plating

MOUNTING EXAMPLE 20

Mounting Example of complete clamp CB5 in Polypropylene with rubber bushing for pipe with outside diameter of 30 mm, mounting rail 28x11 mm.

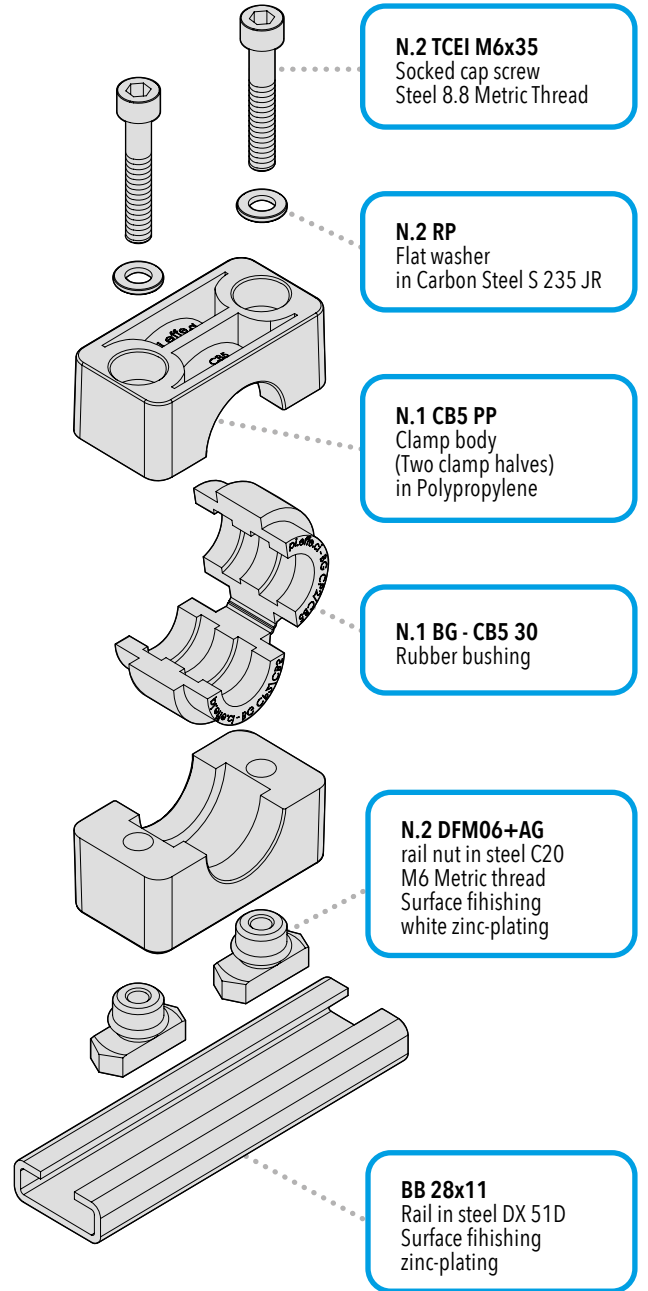

N.2 TCEI M6x35
 Socked cap screw
 Steel 8.8 Metric Thread

N.2 RP
 Flat washer
 in Carbon Steel S 235 JR

N.1 CB5 PP
 Clamp body
 (Two clamp halves)
 in Polypropylene

N.1 BG - CB5 30
 Rubber bushing

N.2 DFM06+AG
 rail nut in steel C20
 M6 Metric thread
 Surface finishing
 white zinc-plating

BB 28x11
 Rail in steel DX 51D
 Surface finishing
 zinc-plating



MOUNTING EXAMPLE 21

Mounting Example of complete clamp C5 in Polypropylene for pipe with outside diameter of 30 mm, mounting rail nut.

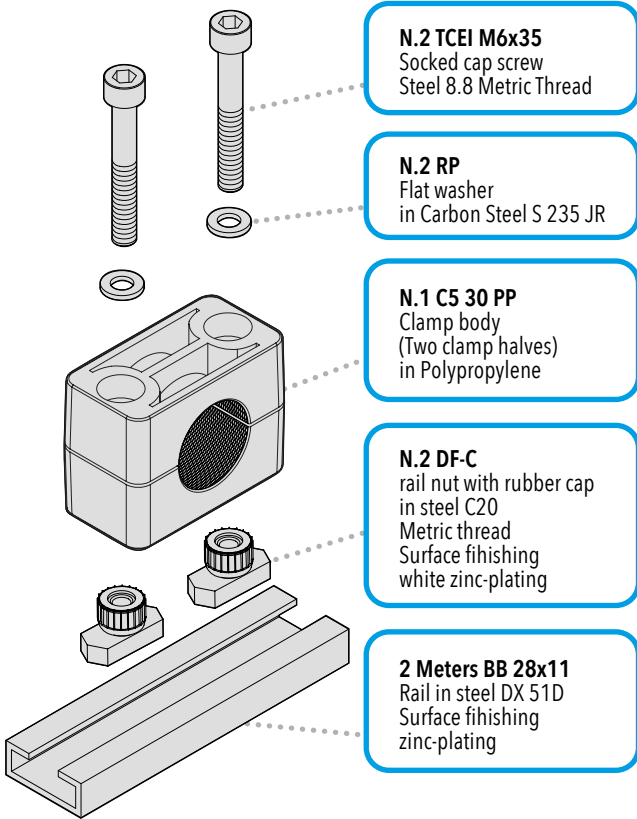

MOUNTING EXAMPLE 22

Mounting Example of complete clamp C5 in Polypropylene for pipe with outside diameter of 30 mm, mounting rail nut and upper plate.

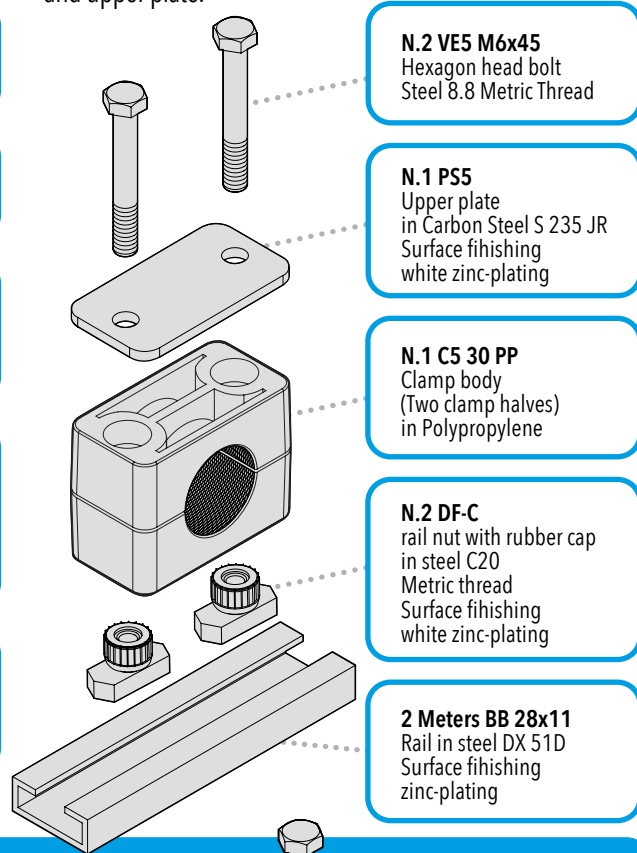

MOUNTING EXAMPLE 23

Mounting Example of complete clamp C5 type side by side in Polypropylene for pipe with outside diameter of 30 mm, with multiple weld plate and upper plate.

