

HYDRAULIC MOTORS MR

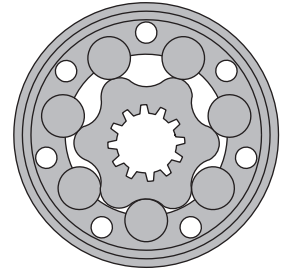

APPLICATION

- » Conveyors
- » Feeding mechanism of robots and manipulators
- » Metal working machines
- » Textile machines
- » Agricultural machines
- » Food industries
- » Grass cutting machinery etc.



CONTENTS

Specification data29+30
 Function diagrams31+39
 Dimensions and mounting 40+41
 Shaft extensions 28
 Permissible shaft loads 29
 Permissible shaft Seal Pressure ... 30
 Order code 42

OPTIONS

- » Model - Spool valve, roll-gerotor
- » Flange mount
- » Motor with needle bearing
- » Side and rear ports
- » Shafts - straight, splined and tapered
- » Shaft seal for high and low pressure
- » Metric and BSPP ports
- » Speed sensing
- » Other special features

GENERAL

Max. Displacement,	cm ³ /rev [in ³ /rev]	397 [24.4]
Max. Speed,	[RPM]	970
Max. Torque,	daNm [lb-in]	cont.: 61 [5400] int.: 69 [6100]
Max. Output,	kW [HP]	15 [20.1]
Max. Pressure Drop,	bar [PSI]	cont.: 175 [2540] int.: 200 [2900]
Max. Oil Flow,	lpm [GPM]	75 [20]
Min. Speed,	[RPM]	10
Pressure fluid		Mineral based- HLP (DIN 51524) or HM (ISO 6743/4)
Temperature range,	°C [°F]	-40÷140 [-40÷284]
Optimal Viscosity range, mm ² /s [SUS]		20÷75 [98÷347]
Filtration		ISO code: 18/16/13 According to ISO 4406-1999

Oil flow in drain line

Pressure drop bar [PSI]	Viscosity mm ² /s [SUS]	Oil flow in drain line lpm [GPM]
100 [1450]	20 [98]	2,5 [.660]
	35 [164]	1,8 [.476]
140 [2030]	20 [98]	3,5 [.925]
	35 [164]	2,8 [.740]

Pressure Losses

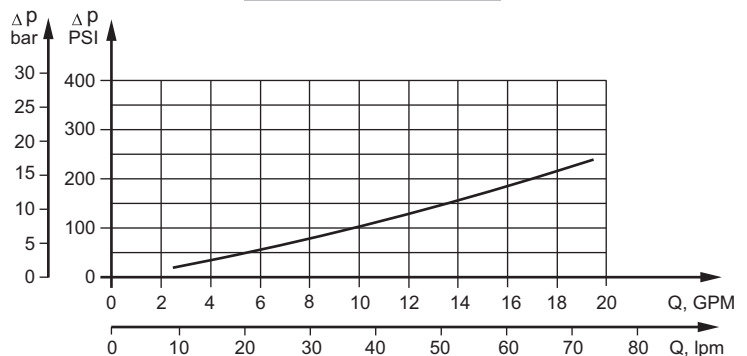

SPECIFICATION DATA

Specification Data for MR... motors with **C, CO, SH, K** and **SA** shafts.
(ø28,56 sealing diameter)

Type		MR 50	MR 80	MR 100	MR 125	MR 160	MR 200	MR 250	MR 315	MR 400
Displacement, cm ³ /rev [in ³ /rev]		51,5 [3.14]	80,3 [4.90]	99,8 [6.09]	125,7 [7.67]	159,6 [9.74]	199,8 [12.19]	250,1 [15.26]	315,7 [19.26]	397 [24.4]
	Max. Speed, [RPM]									
	Cont.	775	750	600	475	375	300	240	190	150
	Int.*	970	940	750	600	470	375	300	240	190
Max. Torque daNm [lb-in]	Cont.	10 [900]	20 [1770]	24 [2125]	30 [2655]	39 [3450]	38,5 [3410]	39 [3450]	36 [3185]	38 [3360]
	Int.*	13 [1150]	22 [1947]	28 [2480]	34 [3010]	43 [3805]	46 [4070]	47 [4160]	47 [4160]	47 [4160]
	Peak**	17 [1505]	27 [2390]	32 [2832]	37 [3275]	46 [4070]	56 [4960]	60 [5310]	61 [5400]	61 [5400]
Max. Output kW [HP]	Cont.	7 [9.5]	12,5 [17]	13 [17.4]	12,5 [16.8]	11,5 [15.4]	9 [12]	8 [10.7]	5 [6.7]	4,8 [6.4]
	Int.*	8,5 [11.9]	15 [20.1]	15 [20.1]	14,5 [19.5]	14 [18.8]	12 [16.1]	9,5 [12.7]	8 [10.7]	6,8 [9.1]
Max. Pressure Drop bar [PSI]	Cont.	140 [2030]	175 [2540]	175 [2540]	175 [2540]	175 [2540]	140 [2030]	110 [1600]	85 [1230]	65 [940]
	Int.*	175 [2540]	200 [2900]	200 [2900]	200 [2900]	200 [2900]	175 [2540]	140 [2030]	115 [1670]	90 [1300]
	Peak**	225 [3260]	225 [3260]	225 [3260]	225 [3260]	225 [3260]	225 [3260]	200 [2900]	150 [2175]	115 [1670]
Max. Oil Flow lpm [GPM]	Cont.	40 [10.5]	60 [15.8]	60 [15.8]	60 [15.8]	60 [15.8]	60 [15.8]	60 [15.8]	60 [15.8]	60 [15.8]
	Int.*	50 [13.2]	75 [19.8]	75 [19.8]	75 [19.8]	75 [19.8]	75 [19.8]	75 [19.8]	75 [19.8]	75 [19.8]
Max. Inlet Pressure bar [PSI]	Cont.	175 [2540]	175 [2540]	175 [2540]	175 [2540]	175 [2540]	175 [2540]	175 [2540]	175 [2540]	175 [2540]
	Int.*	200 [2900]	200 [2900]	200 [2900]	200 [2900]	200 [2900]	200 [2900]	200 [2900]	200 [2900]	200 [2900]
	Peak**	225 [3260]	225 [3260]	225 [3260]	225 [3260]	225 [3260]	225 [3260]	225 [3260]	225 [3260]	225 [3260]
Max. Return Pres- sure with Drain Line bar [PSI]	Cont.	175 [2540]	175 [2540]	175 [2540]	175 [2540]	175 [2540]	175 [2540]	175 [2540]	175 [2540]	175 [2540]
	Int.*	200 [2900]	200 [2900]	200 [2900]	200 [2900]	200 [2900]	200 [2900]	200 [2900]	200 [2900]	200 [2900]
	Peak**	225 [3260]	225 [3260]	225 [3260]	225 [3260]	225 [3260]	225 [3260]	225 [3260]	225 [3260]	225 [3260]
Max. Starting Pressure with Unloaded Shaft, bar [PSI]		10 [145]	10 [145]	10 [145]	9 [130]	7 [102]	5 [73]	4 [58]	3 [44]	3 [44]
Min. Starting Torque daNm [lb-in]	At max.press. drop Cont.	8 [710]	15 [1330]	20 [1770]	25 [2215]	32 2832]	33 [2920]	31 [2740]	31,5 [2875]	31,5 [2875]
	At max.press. drop Int.*	10 [885]	17 [1505]	23 [2035]	28 [2480]	37 [3275]	40 [3540]	48 [4250]	58 [5220]	50 [4425]
Min. Speed***, [RPM]		10	10	10	10	10	10	10	10	10
Weight, kg [lb]	MR(F)	6,8 [15]	6,9 [15.2]	7,2 [15.9]	7,3 [16.1]	7,5 [15.2]	8 [17.6]	8,4 [18.5]	9,1 [20]	9,8 [21.6]
	For rear ports: +0,650 [1.433] MRQ(N)	6,2 [13.7]	6,3 [13.9]	6,6 [14.6]	6,8 [15]	7,2 [14.7]	7,6 [15.4]	7,8 [17.2]	8,6 [19]	9,3 [20.5]

* Intermittent operation: the permissible values may occur for max. 10% of every minute.

** Peak load: the permissible values may occur for max. 1% of every minute.

*** For speeds lower than given, consult factory or your regional manager.

1. Intermittent speed and intermittent pressure must not occur simultaneously.
2. Recommended filtration is per ISO cleanliness code 20/16. A nominal filtration of 25 micron or better.
3. Recommend using a premium quality, anti-wear type mineral based hydraulic oil HLP(DIN51524) or HM (ISO 6743/4).
If using synthetic fluids consult the factory for alternative seal materials.
4. Recommended minimum oil viscosity 13 mm²/s [70 SUS] at 50°C [122°F].
5. Recommended maximum system operating temperature is 82°C [180°F].
6. To assure optimum motor life fill with fluid prior to loading and run at moderate load and speed for 10-15 minutes.

SPECIFICATION DATA (continued)

Specification Data for MR... motors with **CB, KB, OB** and **HB** shafts.
(ø35 sealing diameter)

Type		MR 50	MR 80	MR 100	MR 125	MR 160	MR 200	MR 250	MR 315	MR 400
Displacement, cm ³ /rev [in ³ /rev]		51,5 [3.14]	80,3 [4.90]	99,8 [6.09]	125,7 [7.67]	59,6 [9.74]	199,8 [12.19]	250,1 [15.26]	315,7 [19.26]	397 [24.4]
	Max. Speed, [RPM]									
Max. Torque daNm [lb-in]	Cont.	775	750	600	475	375	300	240	190	150
	Int.*	970	940	750	600	470	375	300	240	190
Max. Output kW [HP]	Cont.	10 [900]	20 [1770]	24 [2125]	30 [2655]	39 [3450]	45 [4000]	54 [4780]	55 [4870]	61 [5400]
	Int.*	13 [1150]	22 [1947]	28 [2480]	34 [3010]	43 [3805]	50 [4425]	61 [5400]	69 [6110]	69 [6110]
	Peak**	17 [1505]	27 [2390]	32 [2832]	37 [3275]	46 [4070]	56 [4960]	71 [6280]	84 [7435]	87 [7700]
Max. Pressure Drop bar [PSI]	Cont.	7 [9.5]	12,5 [17]	13 [17.4]	12,5 [16.8]	11,5 [15.4]	11 [14.8]	10 [13.4]	9 [12]	7,8 [10.5]
	Int.*	8,5 [11.9]	15 [20.1]	15 [20.1]	14,5 [19.5]	14 [18.8]	13 [17.4]	12 [16.1]	10 [13.4]	10,6 [14.2]
	Peak**	140 [2030]	175 [2540]	175 [2540]	175 [2540]	175 [2540]	175 [2540]	175 [2540]	135 [1960]	110 [1600]
Max. Oil Flow lpm [GPM]	Cont.	140 [2030]	175 [2540]	175 [2540]	175 [2540]	175 [2540]	175 [2540]	175 [2540]	135 [1960]	110 [1600]
	Int.*	175 [2540]	200 [2900]	200 [2900]	200 [2900]	200 [2900]	200 [2900]	200 [2900]	175 [2540]	140 [2030]
	Peak**	225 [3260]	225 [3260]	225 [3260]	225 [3260]	225 [3260]	225 [3260]	225 [3260]	210 [3045]	175 [2540]
Max. Inlet Pressure bar [PSI]	Cont.	40 [10.5]	60 [15.8]	60 [15.8]	60 [15.8]	60 [15.8]	60 [15.8]	60 [15.8]	60 [15.8]	60 [15.8]
	Int.*	50 [13.2]	75 [19.8]	75 [19.8]	75 [19.8]	75 [19.8]	75 [19.8]	75 [19.8]	75 [19.8]	75 [19.8]
	Peak**	175 [2540]	175 [2540]	175 [19.8]	175 [2540]	175 [2540]	175 [2540]	175 [2540]	175 [2540]	175 [2540]
Max. Return Pres- sure with Drain Line bar [PSI]	Cont.	200 [2900]	200 [2900]	200 [2540]	200 [2900]	200 [2900]	200 [2900]	200 [2900]	200 [2900]	200 [2900]
	Int.*	225 [3260]	225 [3260]	225 [2900]	225 [3260]	225 [3260]	225 [3260]	225 [3260]	225 [3260]	225 [3260]
	Peak**	175 [2540]	175 [2540]	175 [2540]	175 [2540]	175 [2540]	175 [2540]	175 [2540]	175 [2540]	175 [2540]
Max. Starting Pressure with Unloaded Shaft, bar [PSI]	Cont.	200 [2900]	200 [2900]	200 [2900]	200 [2900]	200 [2900]	200 [2900]	200 [2900]	200 [2900]	200 [2900]
	Int.*	225 [3260]	225 [3260]	225 [3260]	225 [3260]	225 [3260]	225 [3260]	225 [3260]	225 [3260]	225 [3260]
	Peak**	10 [145]	10 [145]	10 [145]	9 [130]	7 [102]	5 [73]	4 [58]	3 [44]	3 [44]
Min. Starting Torque daNm [lb-in]	At max.press. drop Cont.									
	At max.press. drop Int.*	8 [710]	15 [1330]	20 [1770]	25 [2215]	32 [2832]	41 [3630]	50 [4425]	50 [4425]	50 [4425]
	At max.press. drop Int.*	10 [885]	17 [1505]	23 [2035]	28 [2480]	37 [3275]	46 [4070]	55 [4870]	66 [5840]	61 [5400]
Min. Speed***, [RPM]		10	10	10	10	10	10	10	10	10
Weight, kg [lb]										
For rear ports: +0,650 [1.433]		6,9 [15.2]	7 [15.4]	7,3 [16.1]	7,4 [16.3]	7,6 [15.4]	8,1 [18.9]	8,5 [18.7]	9,2 [20.3]	9,9 [21.8]

* Intermittent operation: the permissible values may occur for max. 10% of every minute.

** Peak load: the permissible values may occur for max. 1% of every minute.

*** For speeds lower than given, consult factory or your regional manager.

- Intermittent speed and intermittent pressure must not occur simultaneously.
- Recommended filtration is per ISO cleanliness code 20/16. A nominal filtration of 25 micron or better.
- Recommend using a premium quality, anti-wear type mineral based hydraulic oil HLP(DIN51524) or HM (ISO 6743/4).
If using synthetic fluids consult the factory for alternative seal materials.
- Recommended minimum oil viscosity 13 mm²/s [70 SUS] at 50°C [122°F].
- Recommended maximum system operating temperature is 82°C [180°F].
- To assure optimum motor life fill with fluid prior to loading and run at moderate load and speed for 10-15 minutes.

FUNCTION DIAGRAMS

MR 50

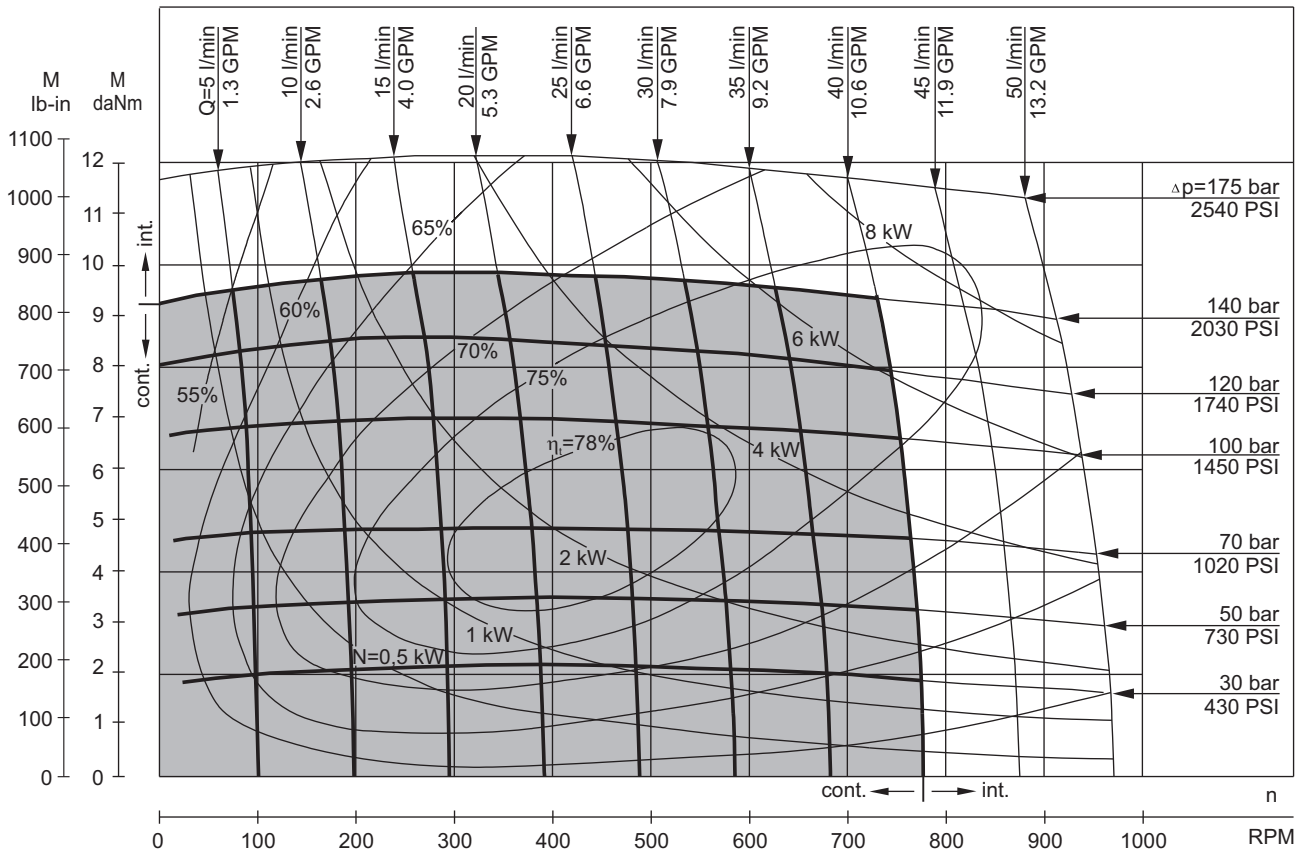

MR 80

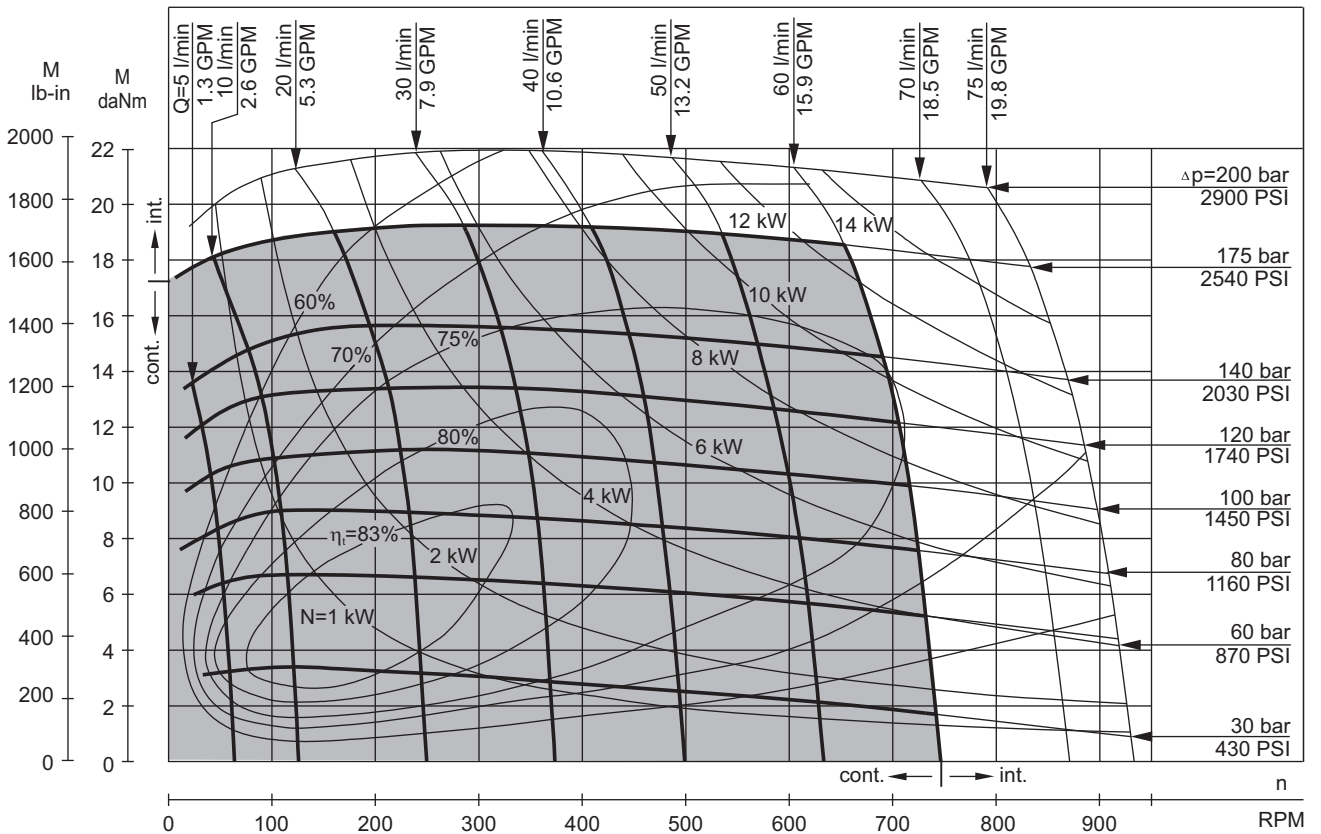

The function diagrams data is for average performance of randomly selected motors at back pressure 5÷10 bar [72.5÷145 PSI] and oil with viscosity of 32 mm²/s [150 SUS] at 50°C [122°F].

FUNCTION DIAGRAMS

MR 100

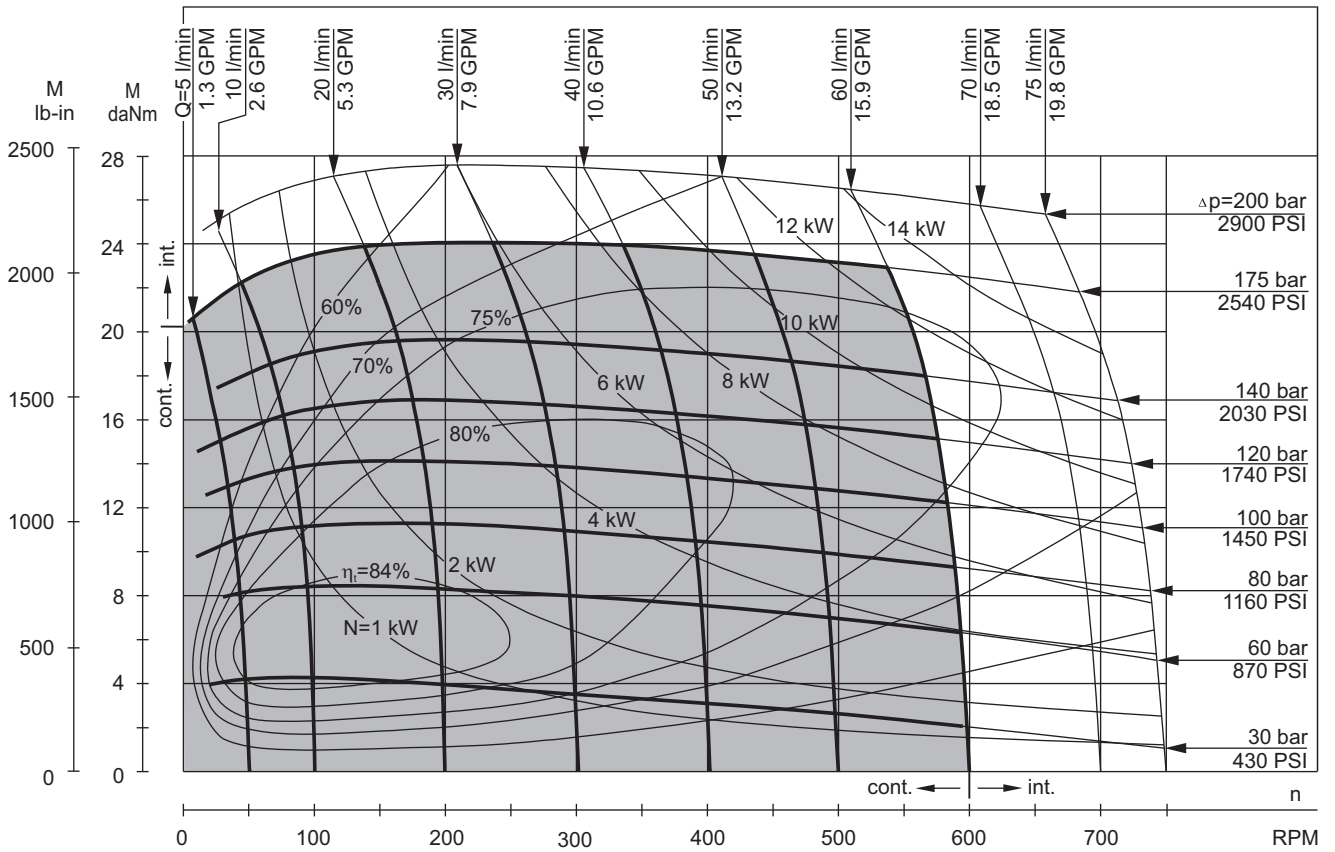

MR 125

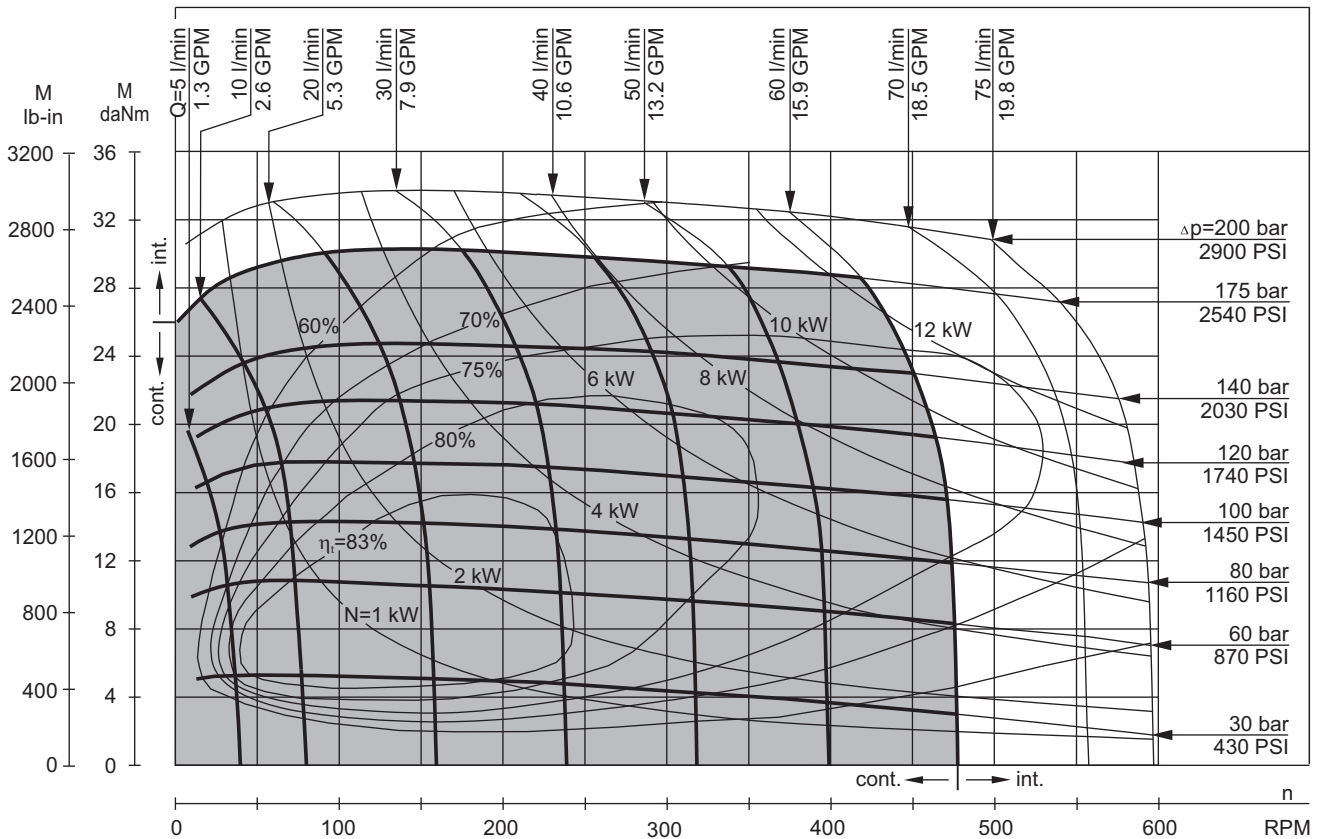

The function diagrams data is for average performance of randomly selected motors at back pressure 5÷10 bar [72.5÷145 PSI] and oil with viscosity of 32 mm²/s [150 SUS] at 50°C [122°F].

FUNCTION DIAGRAMS

MR 160

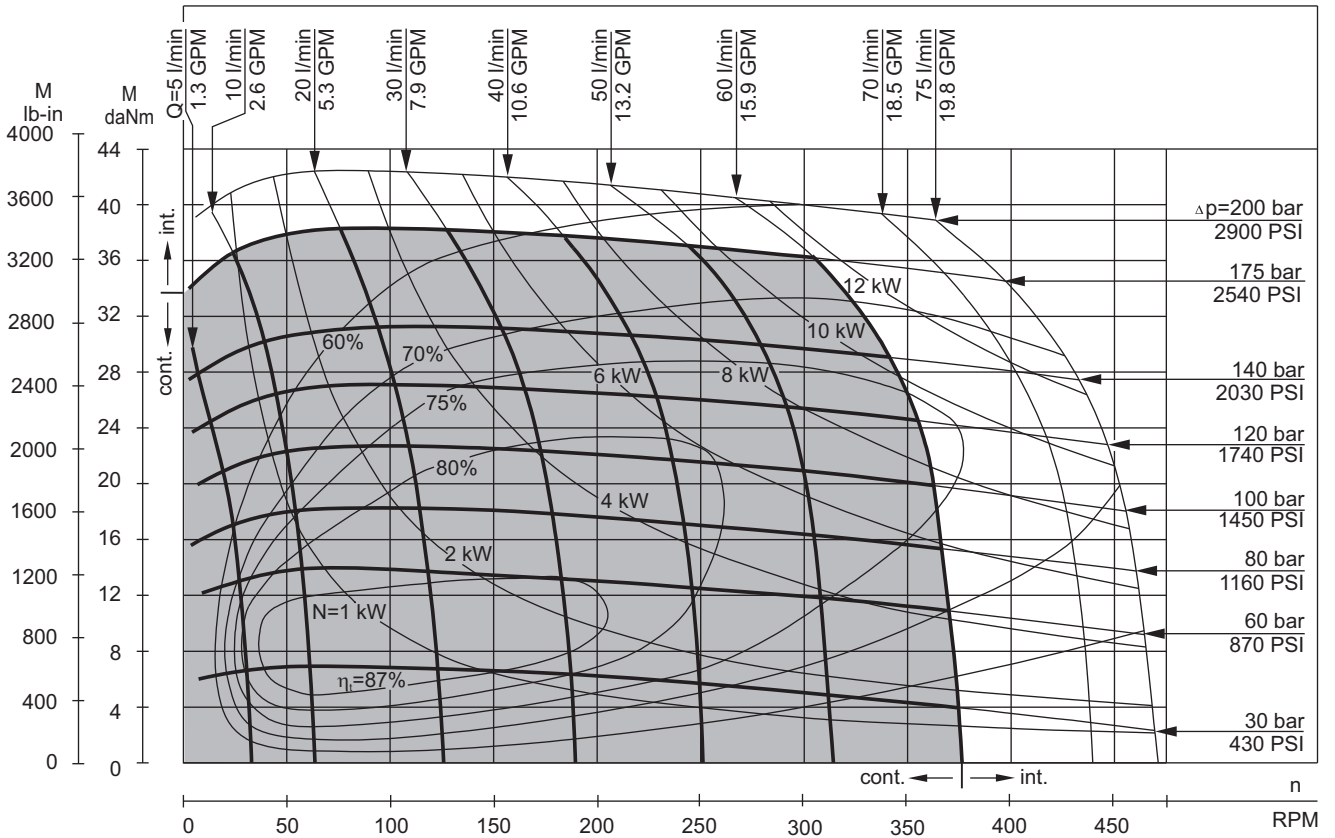

MR 200

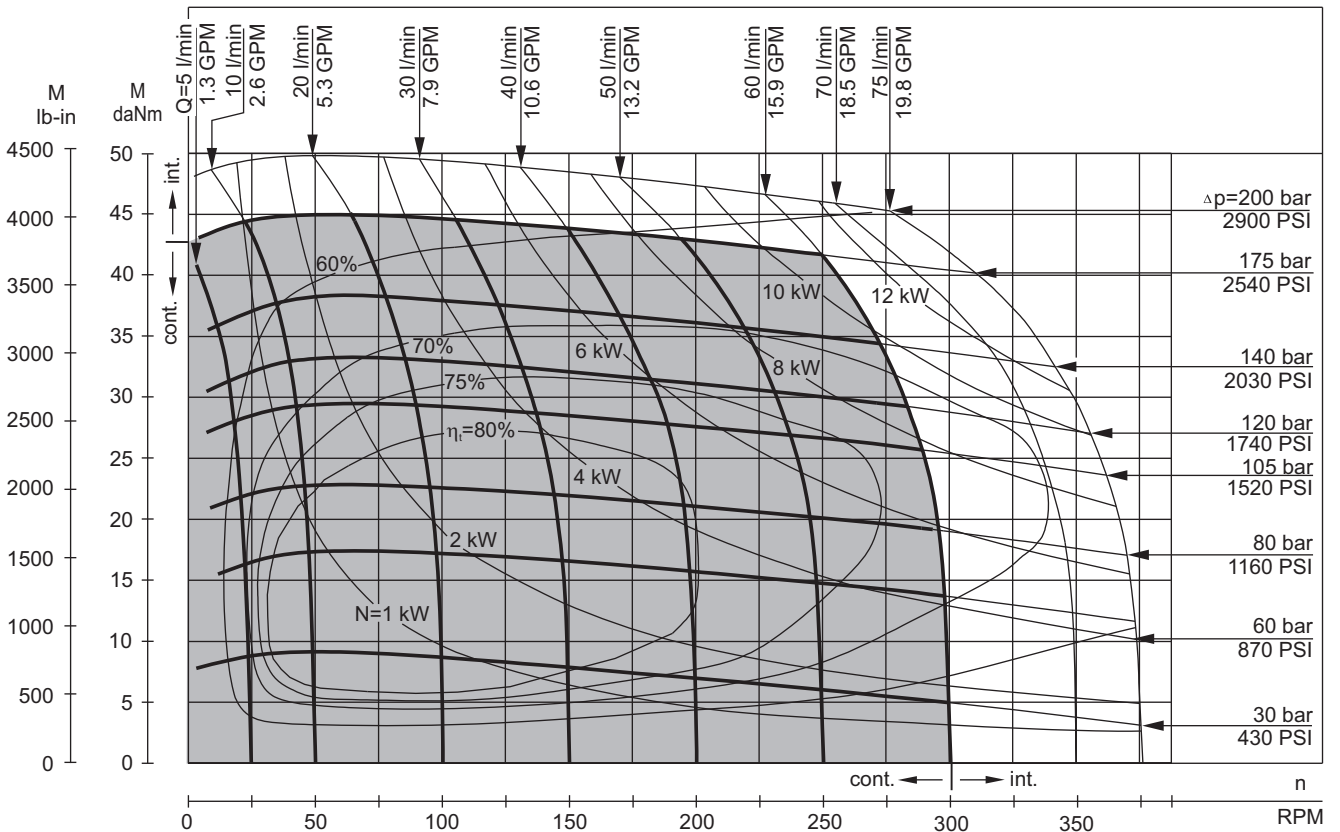

The function diagrams data is for average performance of randomly selected motors at back pressure 5÷10 bar [72.5÷145 PSI] and oil with viscosity of 32 mm²/s [150 SUS] at 50°C [122°F].

FUNCTION DIAGRAMS

MR 250

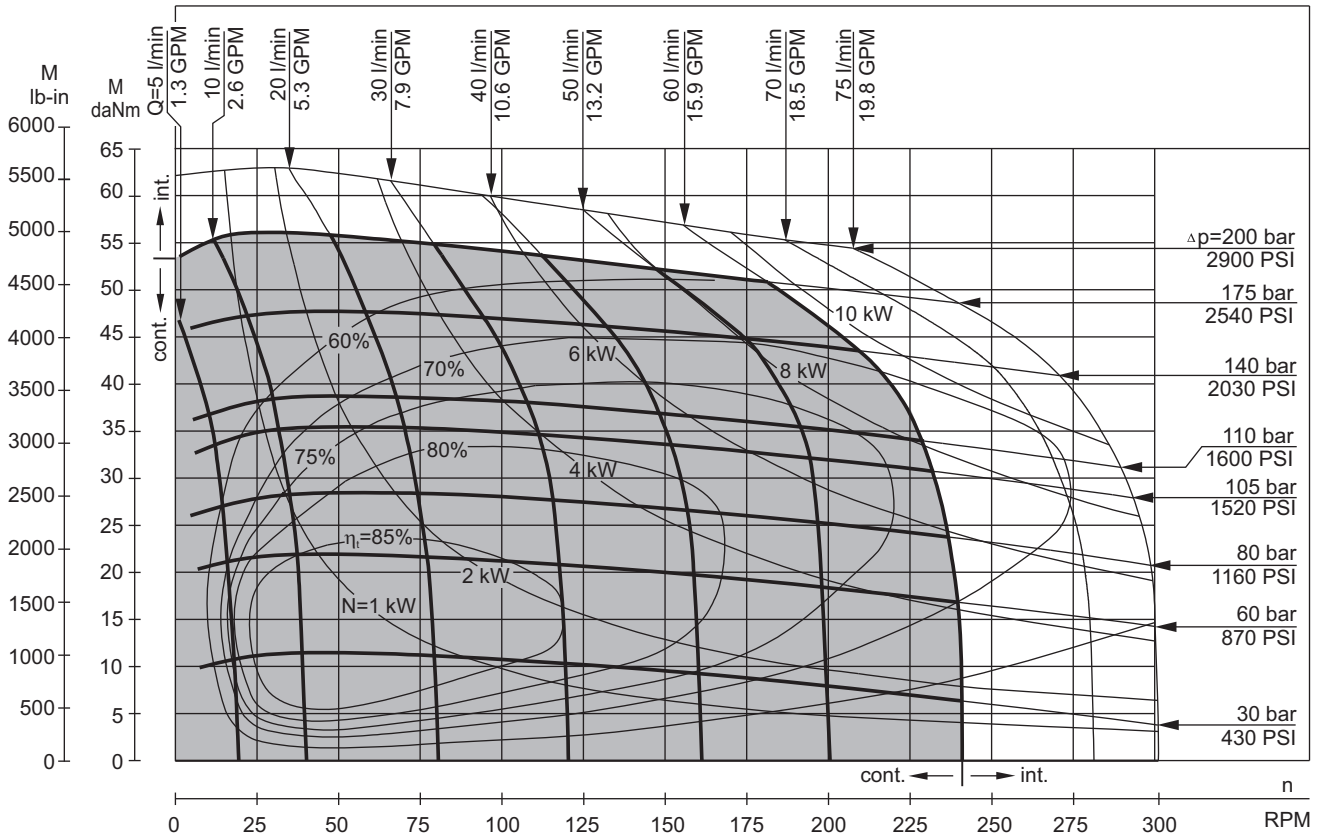

MR 315

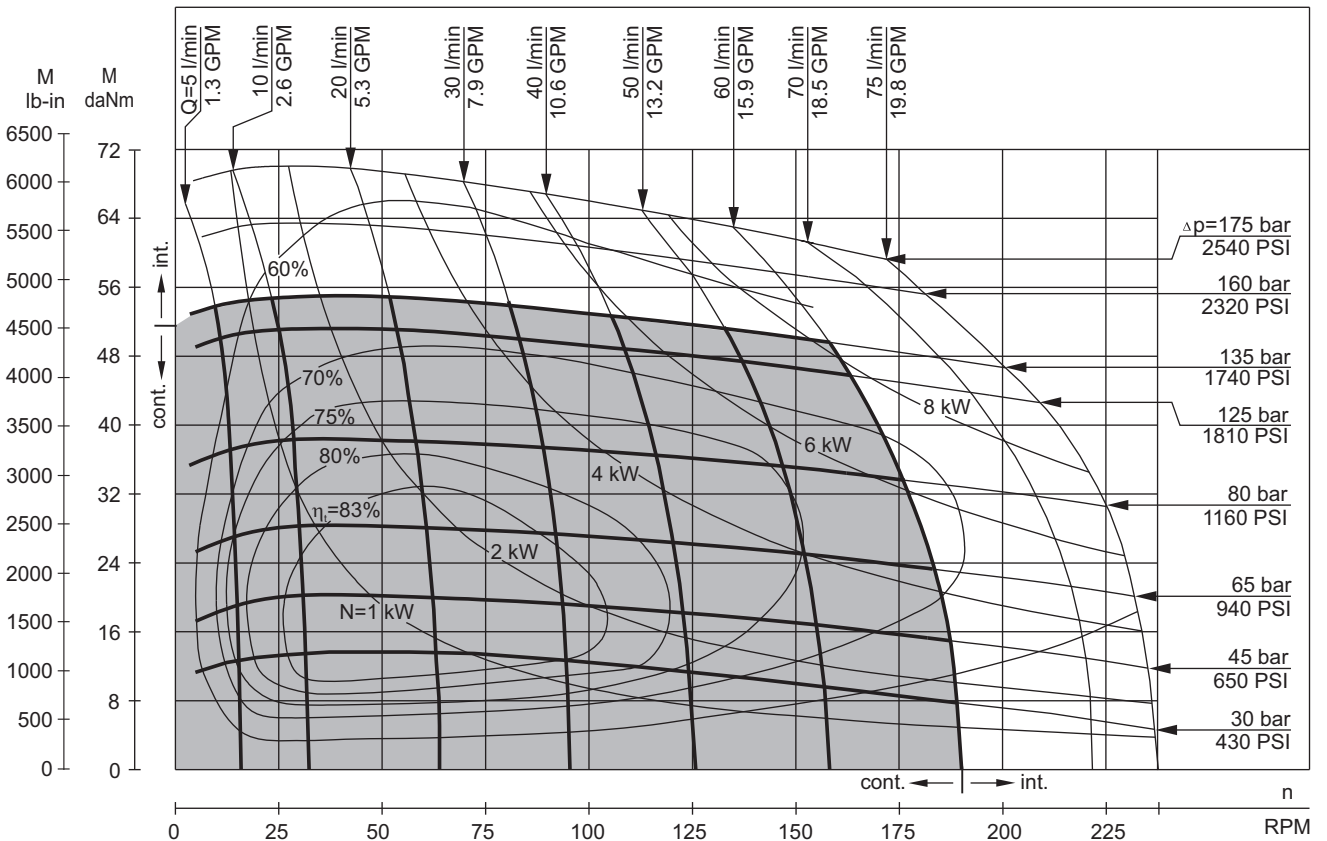

The function diagrams data is for average performance of randomly selected motors at back pressure 5÷10 bar [72.5÷145 PSI] and oil with viscosity of 32 mm²/s [150 SUS] at 50°C [122°F].

FUNCTION DIAGRAMS

MR 400

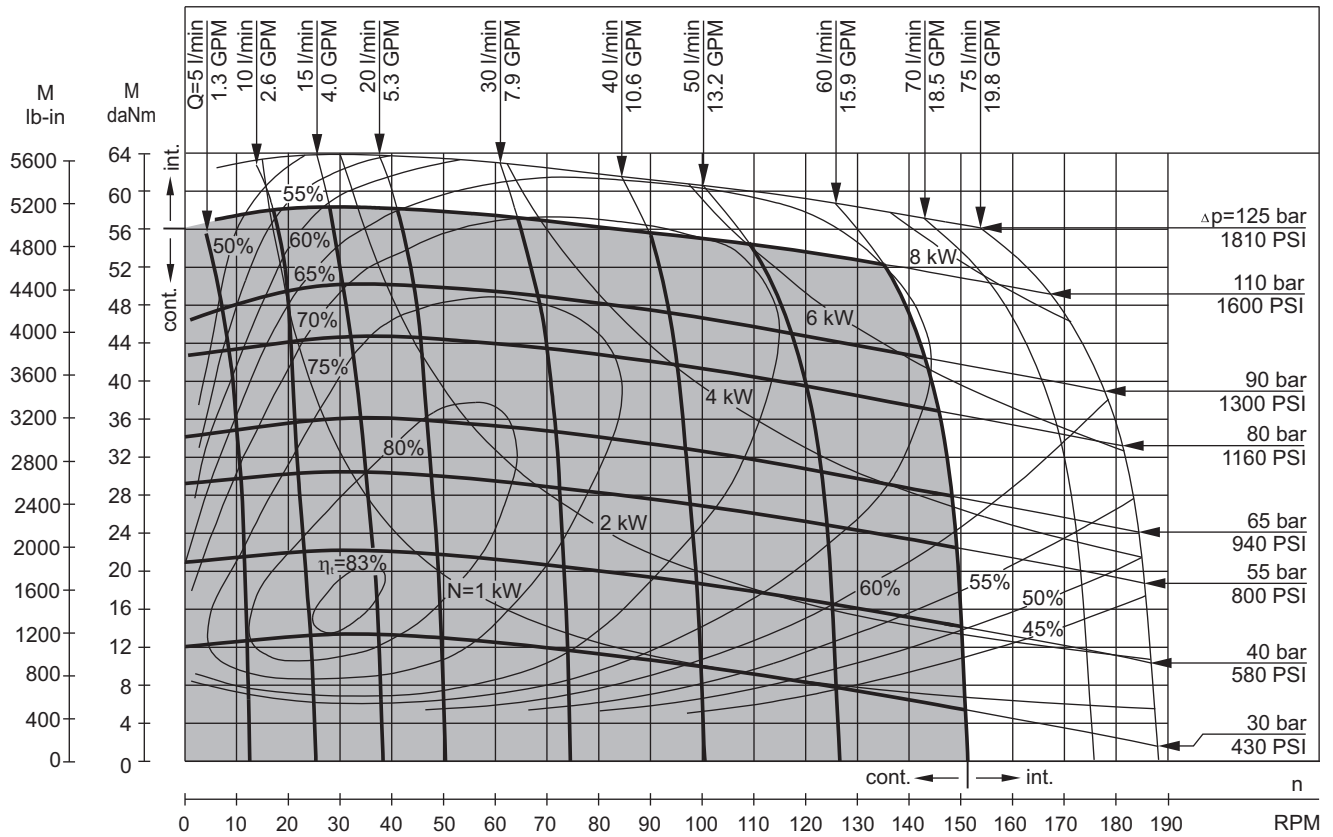

The function diagrams data is for average performance of randomly selected motors at back pressure 5±10 bar [72.5±145 PSI] and oil with viscosity of 32 mm²/s [150 SUS] at 50°C [122°F].

DIMENSIONS AND MOUNTING DATA

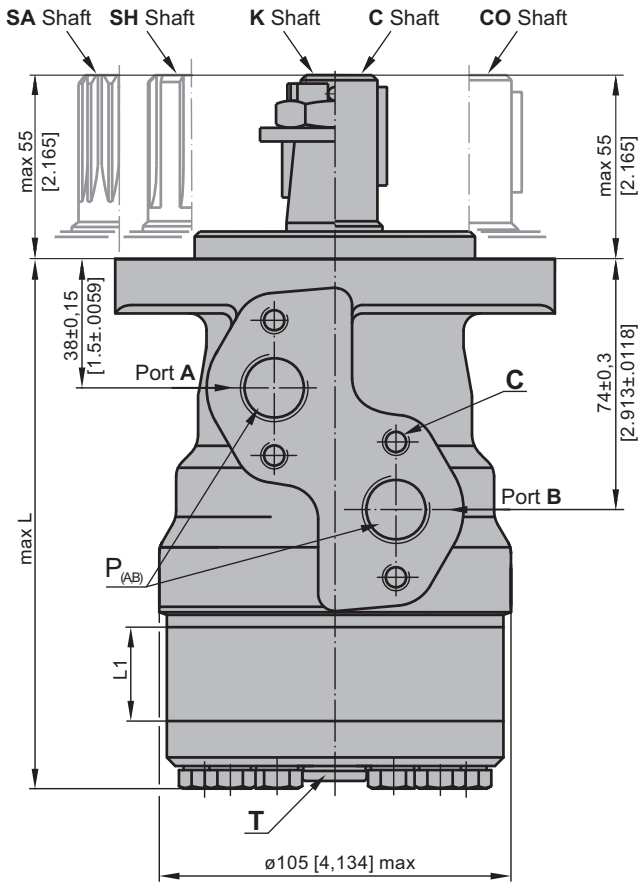

Shaft Dim.
See Page 28

Flange Dim.
See Page 41

Port Dim.
See Page 41

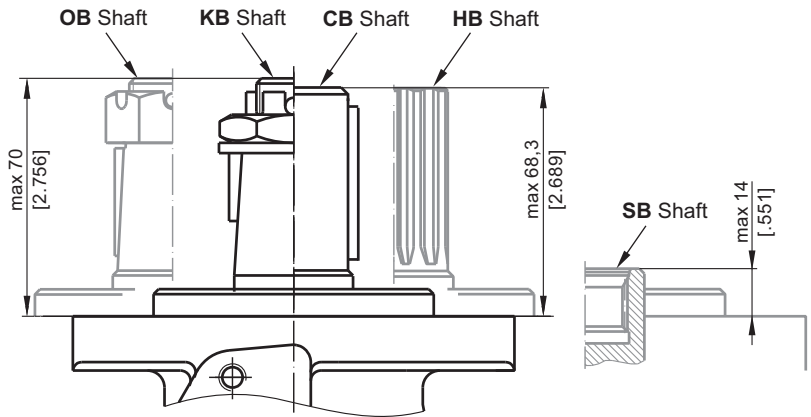
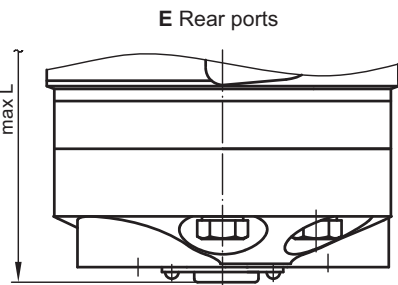
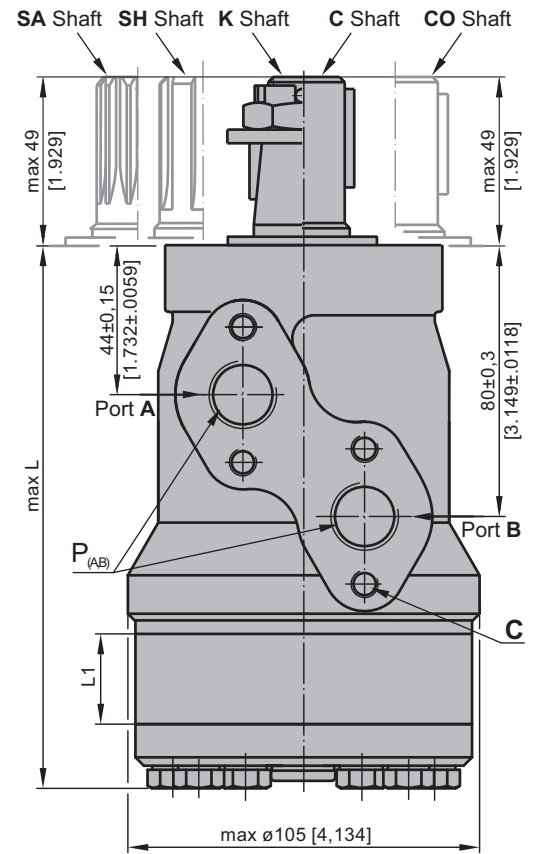

- C** : 4xM8 - 13 mm [.51 in] depth
- P_(A,B)** : 2xG1/2 or 2xM22x1,5 - 15 mm [.59 in] depth
- T** : G1/4 or M14x1,5 - 12 mm [.47 in] depth (plugged)

- | | |
|--|---|
| Standard Rotation
Viewed from Shaft End
Port A Pressurized - CW
Port B Pressurized - CCW | Reverse Rotation
Viewed from Shaft End
Port A Pressurized - CCW
Port B Pressurized - CW |
|--|---|

Type	L, mm [in]	Type	L, mm [in]	Type	L, mm [in]	Type	L, mm [in]	L _r , mm [in]
MR(F) 50	138,0 [5.43]	MRQ 50	143,5 [5.65]	MR(F)E 50	157,5 [6.20]	MRQE 50	163,5 [6.44]	9,0 [.35]
MR(F) 80	143,0 [5.63]	MRQ 80	148,5 [5.85]	MR(F)E 80	162,5 [6.40]	MRQE 80	168,5 [6.63]	14,0 [.55]
MR(F) 100	146,0 [5.75]	MRQ 100	152,0 [5.98]	MR(F)E 100	165,5 [6.52]	MRQE 100	171,5 [6.75]	17,4 [.69]
MR(F) 125	150,5 [5.93]	MRQ 125	156,5 [6.16]	MR(F)E 125	170,0 [6.69]	MRQE 125	176,0 [6.93]	21,8 [.86]
MR(F) 160	156,5 [6.16]	MRQ 160	162,5 [6.40]	MR(F)E 160	176,0 [6.93]	MRQE 160	182,0 [7.17]	27,8 [1.09]
MR(F) 200	163,5 [6.44]	MRQ 200	169,5 [6.67]	MR(F)E 200	183,0 [7.20]	MRQE 200	189,0 [7.44]	34,8 [1.37]
MR(F) 250	172,0 [6.77]	MRQ 250	179,0 [7.05]	MR(F)E 250	192,0 [7.56]	MRQE 250	198,0 [7.80]	43,5 [1.71]
MR(F) 315	183,0 [7.20]	MRQ 315	189,0 [7.44]	MR(F)E 315	204,0 [8.03]	MRQE 315	210,0 [8.27]	54,8 [2.16]
MR(F) 400	198,0 [7.80]	MRQ 400	204,0 [8.03]	MR(F)E 400	218,0 [8.58]	MRQE 400	224,0 [8.82]	69,4 [2.73]

MOUNTING

Oval Mount (2 Holes)

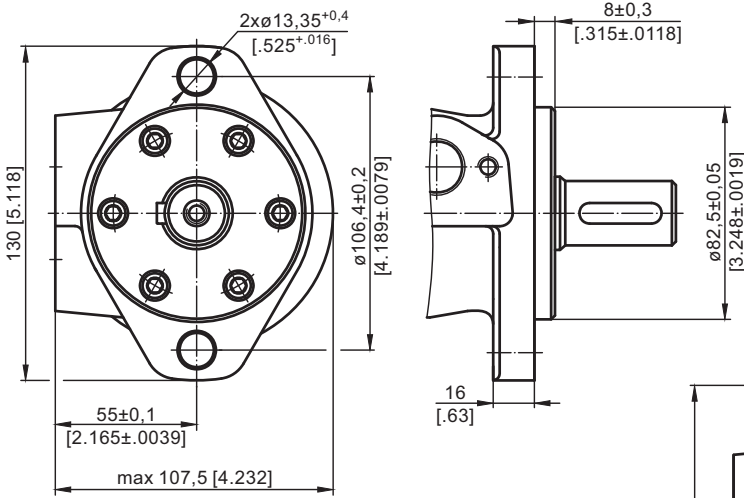

F - Oval Mount (4 Holes)

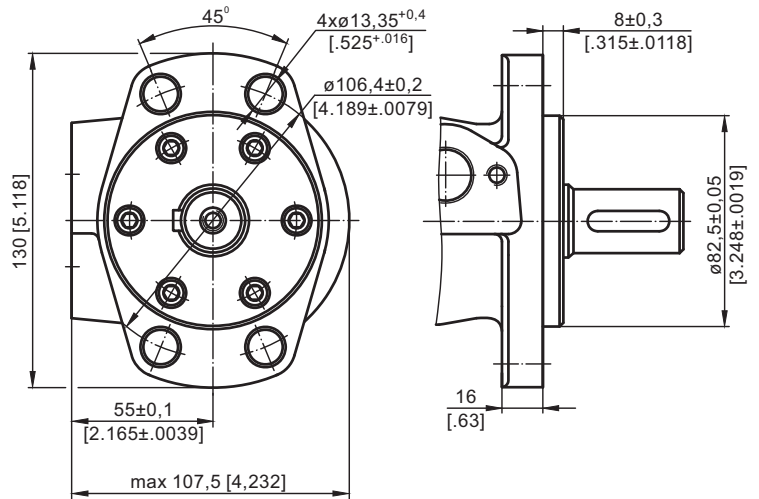

Q - Square Mount (4 Bolts)

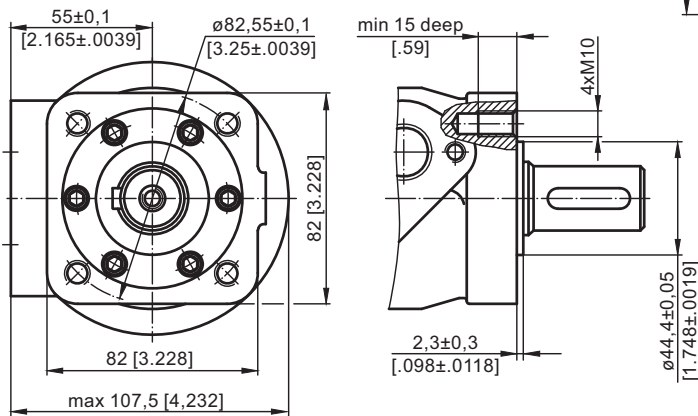

PORTS

Side Ports

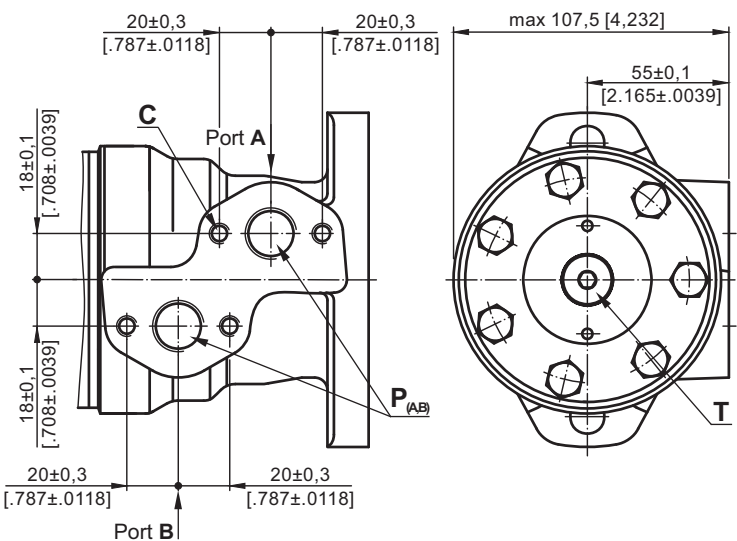

E Rear Ports

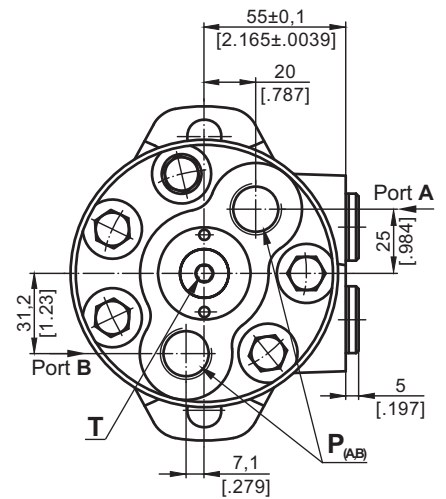

- C** : 4xM8 - 13 mm [0.51 in] depth
- P_(A,B)** : 2xG1/2 or 2xM22x1,5 - 15 mm [0.59 in] depth
- T** : G1/4 or M14x1,5 - 12 mm [0.47 in] depth (plugged)

Standard Rotation

Viewed from Shaft End

Port A Pressurized - CW

Port B Pressurized - CCW

Reverse Rotation

Viewed from Shaft End

Port A Pressurized - CCW

Port B Pressurized - CW

ORDER CODE

	1	2	3	4	5	6	7	8	9	10
MR										

Pos.1 - Mounting Flange

- omit - Oval mount, two holes
- F** - Oval mount, four holes
- Q** - Square mount, four bolts

Pos.2 - Option (needle bearings)

- omit - none
- N** - with needle bearings

Pos.3 - Port type

- omit - Side ports
- E** - Rear ports

Pos.4 - Displacement code

- 50** - 51,5 cm³/rev [3.14 in³/rev]
- 80** - 80,3 cm³/rev [4.90 in³/rev]
- 100** - 99,8 cm³/rev [6.09 in³/rev]
- 125** - 125,7 cm³/rev [7.67 in³/rev]
- 160** - 159,6 cm³/rev [9.74 in³/rev]
- 200** - 199,8 cm³/rev [12.19 in³/rev]
- 250** - 250,1 cm³/rev [15.26 in³/rev]
- 315** - 315,7 cm³/rev [19.26 in³/rev]
- 400** - 397,0 cm³/rev [24.40 in³/rev]

Pos.5 - Shaft Extensions* (see page 28)

- C** - \varnothing 25 straight, Parallel key A8x7x32 DIN6885
- VC** - \varnothing 25 straight, Parallel key A8x7x32 DIN6885 with corrosion resistant bushing
- CO** - \varnothing 1" straight, Parallel key 1/4"x1/4"x1 1/4" BS46
- VCO** - \varnothing 1" straight, Parallel key 1/4"x1/4"x1 1/4" Bs46 with corrosion resistant bushing
- SH** - \varnothing 25,32 splined BS 2059 (SAE 6B)
- VSH** - \varnothing 25,32 splined BS 2059 (SAE 6B) with corrosion resistant bushing
- K** - \varnothing 28,56 tapered 1:10, Parallel key B5x5x14 DIN6885
- SA** - \varnothing 24,5 splined B 25x22 DIN 5482
- VSA** - \varnothing 24,5 splined B 25x22 DIN 5482 with corrosion resistant bushing
- CB** - \varnothing 32 straight, Parallel key A10x8x45 DIN6885
- KB** - \varnothing 35 tapered 1:10, Parallel key B6x6x20 DIN6885
- SB** - splined A 25x22 DIN 5482
- OB** - \varnothing 1 1/4" tapered 1:8, Parallel key 5/16"x5/16"x1 1/4" BS46
- HB** - \varnothing 1 1/4" splined 14T ANSI B92.1 - 1976

Pos. 6 - Shaft Seal Version (see page 30)

- omit - Low pressure shaft seal or Standard shaft seal for "...B" shaft
- D** - Standard shaft seal
- U** - High pressure shaft seal (without check valves)

Pos. 7 - Drain Port

- omit - with drain port
- 1** - without drain port

Pos. 8 - Ports

- omit - BSPP (ISO 228)
- M** - Metric (ISO 262)

Pos. 9 - Special Features (see page 120)

Pos.10 - Design Series

- omit - Factory specified

NOTES: The following combinations are not allowed: - **Q** flange with "...B" shafts;
 - **N** option with "...B" shafts, Low Pressure Seal or **U** option;
 - "...B" shafts with **D** and **U** shaft seals.

* The permissible output torque for shafts must not be exceeded!

The hydraulic motors are manganese-phosphatized as standard.

Hydraulic motors type MR...T with tacho connection

MR motors are available in version with tacho drive shaft. With tacho connection the speed of the motor can be registered. Tacho shaft has a 6 times higher revolution speed than output shaft and opposite direction of rotation.

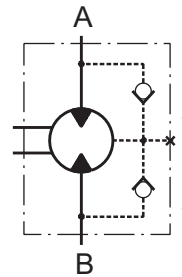

OUTLINE DIMENSIONS REFERENCE

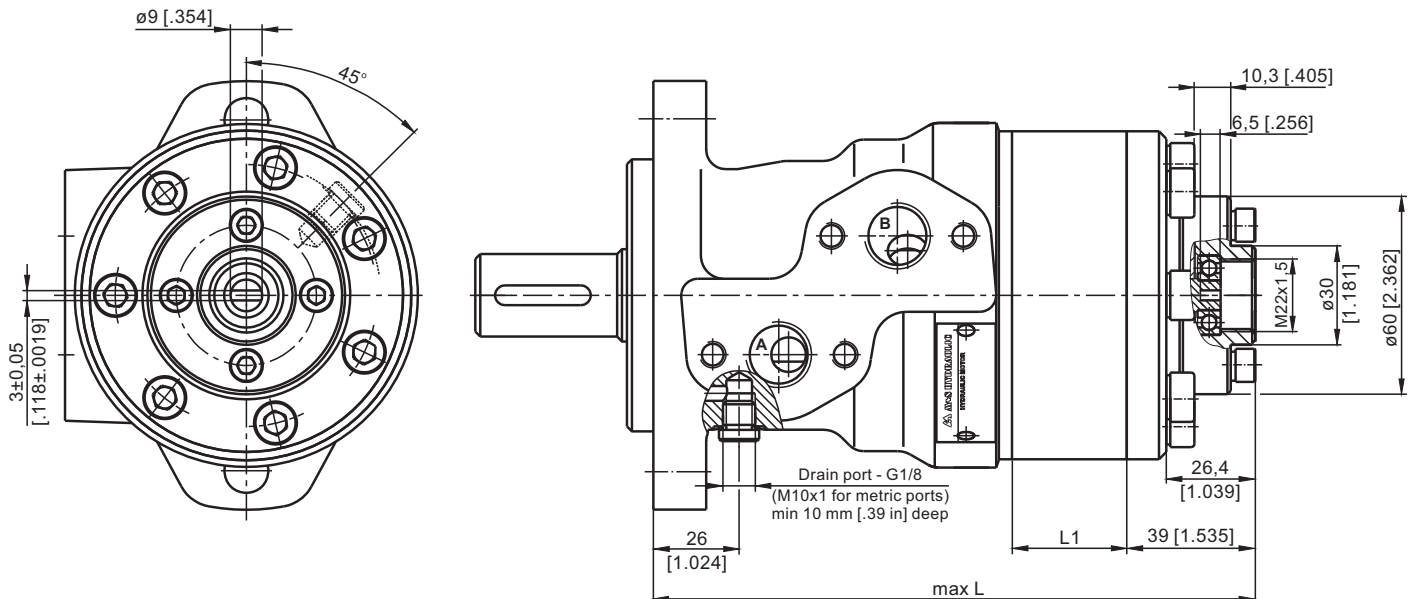

Type	L, mm [in]	L ₁ , mm [in]
MR 50	157 [6.18]	9,0 [.35]
MR 80	162 [6.38]	14,0 [.55]
MR 100	165 [6.50]	17,4 [.69]
MR 125	170 [6.69]	21,8 [.86]
MR 160	176 [6.93]	27,8 [1.09]
MR 200	183 [7.20]	34,8 [1.37]
MR 250	192 [7.56]	43,5 [1.71]
MR 315	204 [8.03]	54,8 [2.16]
MR 400	218 [8.58]	69,4 [2.73]



Notes:

Radial or axial load on tacho shaft must be avoided. Max. torque on tacho shaft 0,1 daNm [.885 lb-in]. Max. cont. return pressure without drain line 20 bar [290 PSI].

Tacho option for MR motor is available only for shafts with sealing diameter $\varnothing 28,56$ with shaft seal type **D** (up to 150 bar).

It is not allowed for Q-flange.

The main technical features correspond to the standard motors series MR. There are no changes in the overall and mounting dimensions. For detail technical and mounting data please refer to MR catalogue.

MOTOR SPECIAL FEATURES

Special Feature Description	Order Code	Motor type														
		MM	MP	MPW	MP(W)N	MR	MRN	MRB	SP, SR	PL	RL	PK(Q)	RK	RW	MH	HW
Speed Sensor*	RS	O	O	-	-	O	-	-	-	-	-	-	-	-	O	O*****
Tacho connection	T	-	-	-	-	O	O	-	-	-	-	-	-	-	O	-
Low Leakage	LL	O	-	-	-	O	O	-	-	-	O	-	O	O	O	O
Low Speed Valving	LSV	-	-	-	-	O	-	-	-	-	-	-	-	-	O	O
Free Running	FR	O	O	O	O	O	O	-	-	O	O	O	O	O	O	O
Reverse Rotation	R	O	O	O	O	O	O	O	O	O	O	O	O	O	O	O
Paint**	P	O	O	O	O	O	O	O	O	O	O	O	O	O	O	O
Corrosion Protected Paint**	PC	O	O	O	O	O	O	O	O	O	O	O	O	O	O	O
Special Paint***	PS	O	O	O	O	O	O	O	-	O	O	O	O	O	O	O
	PCS	O	O	O	O	O	O	O	O	O	O	O	O	O	O	O
Check Valves		S	S****	S****	S	S****	S	S	S	S	S	S	S	S****	S****	S

O	Optional
-	Not applicable
S	Standard

- * For sensor ordering see pages 121÷122.
- ** Colour at customer's request.
- *** Non painted feeding surfaces, colour at customer's request.
- **** Without check valves for "U" shaft seal versions.
- ***** RS option is not available at HW...R (with relief valves).

MOTORS WITH SPEED SENSOR

MM...RS

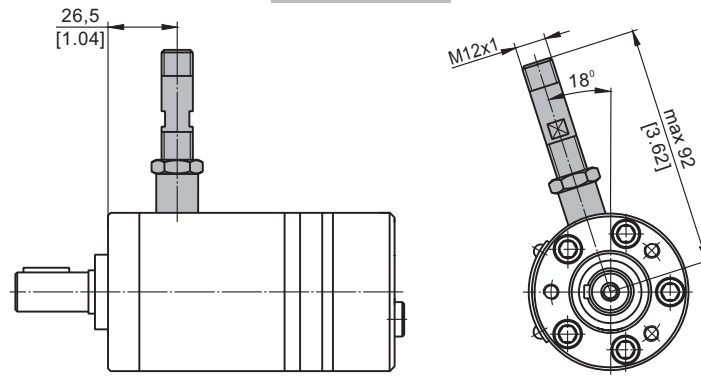

MP...RS and MR...RS

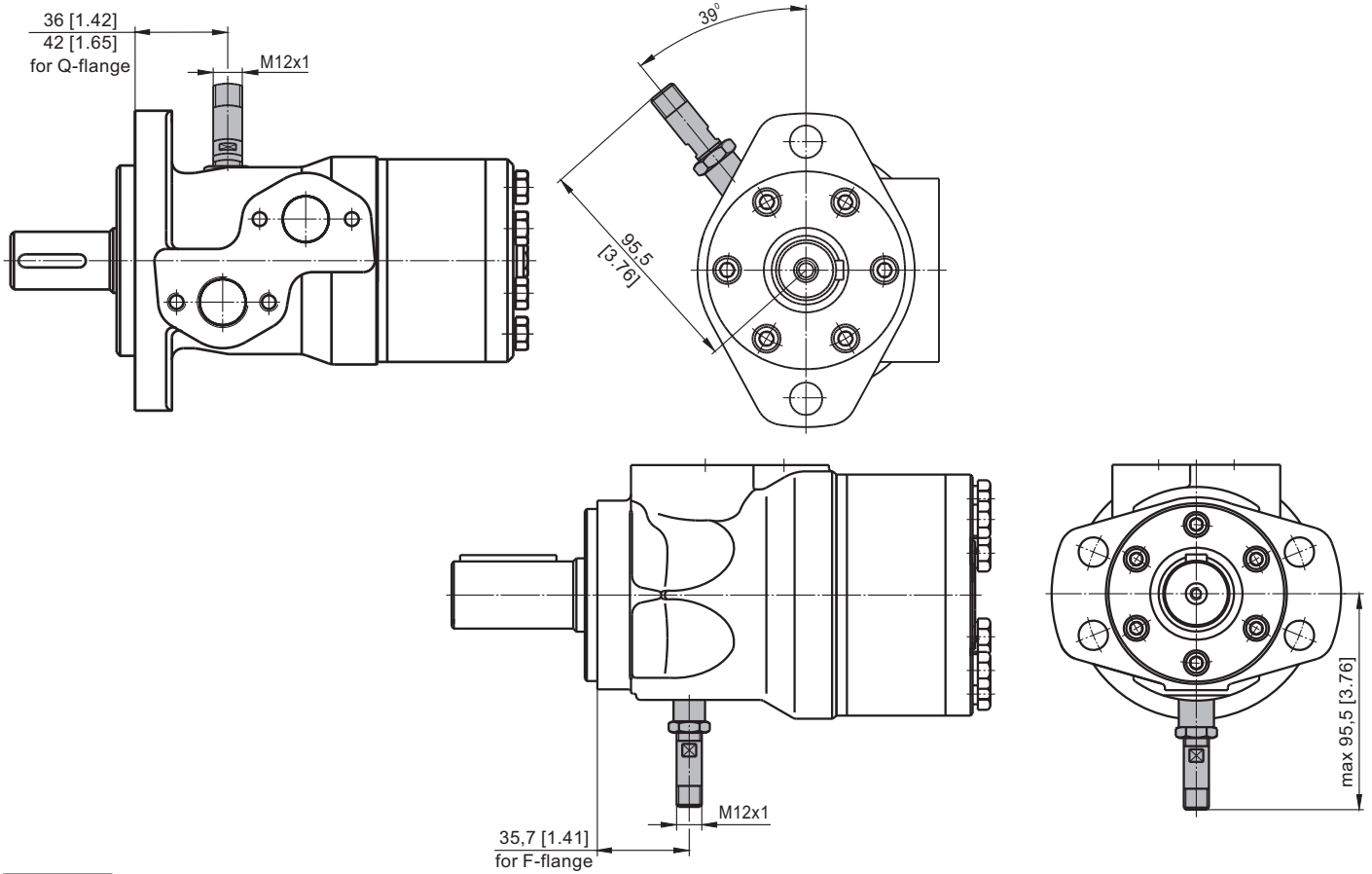

MH...RS

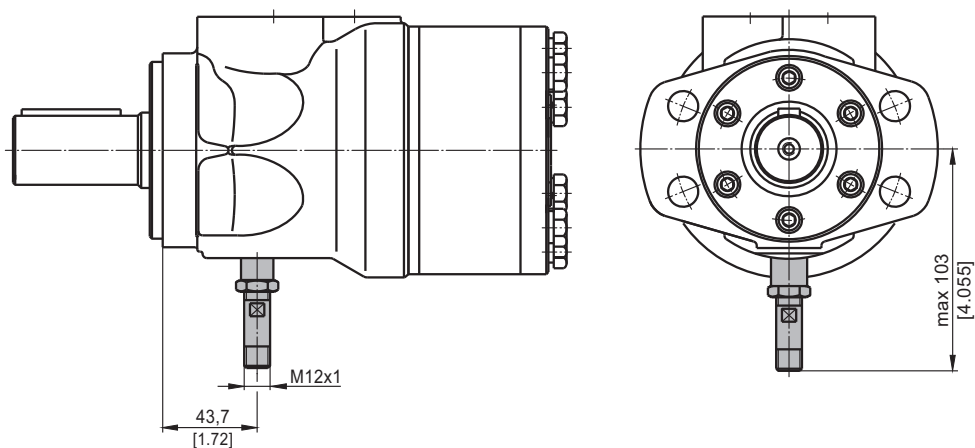

HW...RS

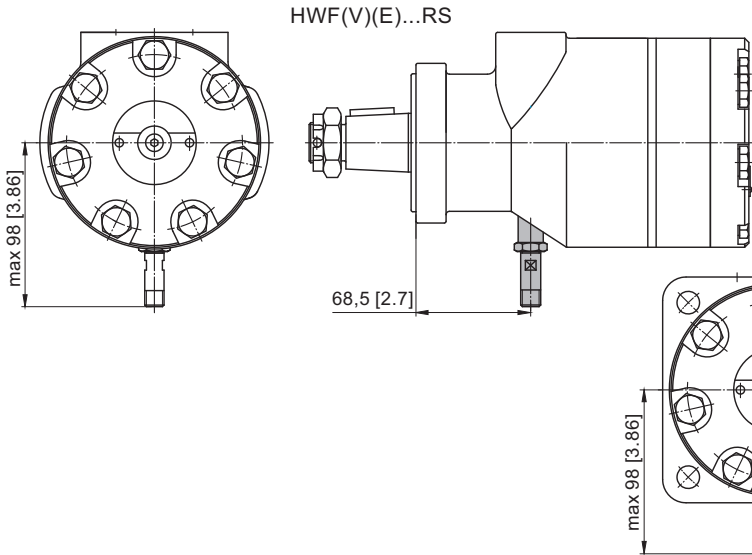

RS option is not available at HW...R (with relief valves).

HW(S)(D)(SW)(V)(E)...RS

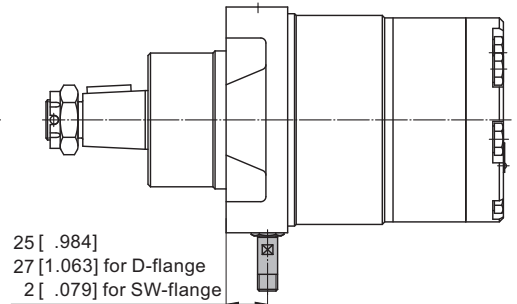

TECHNICAL DATA OF THE SPEED SENSOR

Technical data

Frequency range	0...15 000 Hz
Output	Universal PUSH PULL
Power supply	10-30 VDC
Current input	<20 mA (@24 VDC)
Maximum output current	500 mA
Ambient Temperature	-40...+125°C [-40...+257°F]
Protection	IP 67
Plug connector	M12-Series
Mounting principle	ISO 6149

Output signal

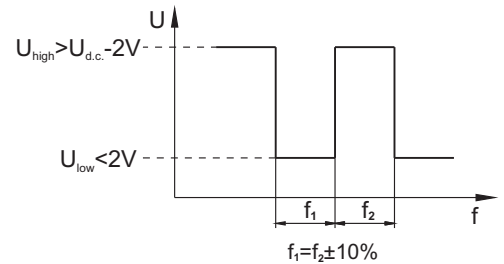

Load max.: $i_{high} = i_{low} < 50\text{mA}$

Motor type	MM	MP	MR	MH	HW
Pulses per revolution	30	36	36	42	12

Wiring diagrams

PNP

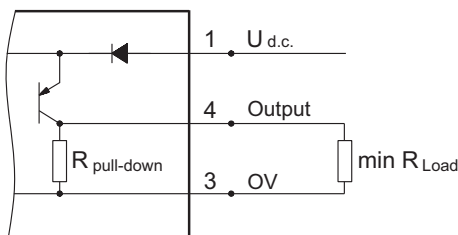

NPN

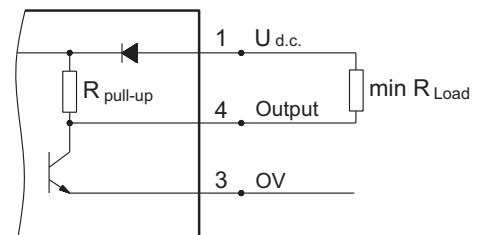

$$R_{Load} [k\Omega] = U_{d.c.} [V] / I_{max} [mA]$$

Stick type

Order Code for Speed Sensor

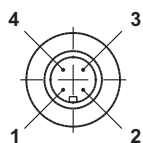

Terminal No.	Connection	Cable Output
1	U _{d.c.}	Brown
2	No connection	White
3	0V	Blue
4	Output signal	Black

Sensor Code	Electric connection
RS	Connector BINDER 713 series
RSL2,5	Cable output 3x0,25; 2,5 m [98 in] long
RSL3,5	Cable output 3x0,25; 3,5 m [138 in] long
RSL5	Cable output 3x0,25; 5 m [196 in] long
RSL10	Cable output 3x0,25; 10 m [394 in] long

NOTE: * - The speed sensor is not fitted at the factory, but is supplied in a plastic bag with the motor. For installation see enclosed instructions.

APPLICATION CALCULATION

VEHICLE DRIVE CALCULATIONS

1. Motor speed: n [RPM]

$$n = \frac{2.65 \times v_{km} \times i}{R_m} \quad n = \frac{2168 \times v_{mi} \times i}{R_{in}}$$

v_{km} - vehicle speed, km/h;

v_{mi} - vehicle speed, mil/h;

R_m - wheel rolling radius, m;

R_{in} - wheel rolling radius, in;

i - gear ratio between motor and wheels.

If no gearbox, use $i=1$.

2. Rolling resistance: RR, daN [lbs]

The resistance force resulted in wheels contact with different surfaces:

$$RR = G \times \rho$$

G - total weight loaded on vehicle, daN [lbs];

ρ - rolling resistance coefficient (Table 1).

Table 1

Rolling resistance coefficient In case of rubber tire rolling on different surfaces	
Surface	ρ
Concrete- faultless	0.010
Concrete- good	0.015
Concrete- bad	0.020
Asphalt- faultless	0.012
Asphalt- good	0.017
Asphalt- bad	0.022
Macadam- faultless	0.015
Macadam- good	0.022
Macadam- bad	0.037
Snow- 5 cm	0.025
Snow- 10 cm	0.037
Polluted covering- smooth	0.025
Polluted covering- sandy	0.040
Mud	0.037÷0.150
Sand- Gravel	0.060÷0.150
Sand- loose	0.160÷0.300

3. Grade resistance: GR, daN [lbs]

$$GR = G \times (\sin\alpha + \rho \times \cos\alpha)$$

α - gradient negotiation angle (Table 2).

Table 2

Grade %	α Degrees	Grade %	α Degrees
1%	0° 35'	12%	6° 5'
2%	1° 9'	15%	8° 31'
5%	2° 51'	20%	11° 19'
6%	3° 26'	25%	14° 3'
8%	4° 35'	32%	18°
10%	5° 43'	60%	31°

4. Acceleration force: FA, daN [lbs]

Force FA necessary for acceleration from 0 to maximum speed v and time t can be calculated with a formula:

$$FA = \frac{v_{km} \times G}{36 \times t}, \text{ [daN]} \quad FA = \frac{v_{mi} \times G}{22 \times t}, \text{ [lbs]}$$

R - acceleration force, daN [lbs];

t - time, [s]

5. Tractive effort: DP, daN [lbs]

Tractive effort DP is the additional force of trailer. This value will be established as follows:

- acc. to constructor's assessment;

- as calculating forces in items 2, 3 and 4 of trailer;

the calculated sum corresponds to the tractive effort requested.

6. Total tractive effort: TE, daN [lbs]

Total tractive effort TE is total effort necessary for vehicle motion; that the sum of forces calculated in items from 2 to 5 and increased with 10% because of air resistance.

$$TE = 1,1 \times (RR + GR + FA + DP)$$

RR - force acquired to overcome the rolling resistance;

GR - force acquired to slope upwards;

FA - force acquired to accelerate (acceleration force);

DP - additional tractive effort (trailer).

7. Motor Torque moment: M, daNm [lb-in]

Necessary torque moment for every hydraulic motor:

$$M = \frac{TE \times R_{in} [R_m]}{N \times i \times h_M}$$

N - motor numbers;

η_M - mechanical gear efficiency (if it is available).

8. Cohesion between tire and road covering:

M_w , daNm [lb-in]

Necessary torque moment for every hydraulic motor:

$$M_w = \frac{M_w \times f \times R_{in} [R_m]}{l \times h_M}$$

To avoid wheel slipping, the following condition should be observed $M_w > M$

f - frictional factor;

G_w - total weight over the wheels, daN [lbs].

Table 3

Surface	Frictional factor f
Steel on steel	0.15 ÷ 0.20
Rubber tire on polluted surface	0.5 ÷ 0.7
Rubber tire on asphalt	0.8 ÷ 1.0
Rubber tire on concrete	0.8 ÷ 1.0
Rubber tire on grass	0.4

9. Radial motor loading: P_{rad} , daN [lbs]

When motor is used for vehicle motion with wheels mounted directly on motor shaft, the total radial loading of motor shaft P_{rad} is a sum of motion force and weight force acting on one wheel.

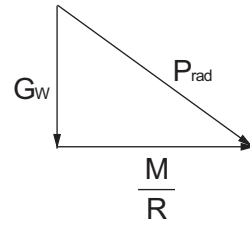

G_w - weight held by wheel;

P_{rad} - total radial loading of motor shaft;

M/R - motion force.

$$P_{rad} = \sqrt{G_w^2 + \left(\frac{M}{R}\right)^2}$$

In accordance with calculated loadings the suitable motor from the catalogue is selected.

DRAINAGE SPACE AND DRAINAGE PRESSURE

Advantages in oil drainage from drain space: Cleaning; Cooling and Seal lifetime prolonging.

