



PIPE CLAMPS **SPECIAL SERIES**

CLAMP BODY STANDARD MATERIALS



Polypropylene
Colour **Blue**
Code **PP**

**OTHER COLOURS
AVAILABLE ON DEMAND!**



Polyamide
Colour **Black**
Code **PA**



Rubber Elastomer
Colour **Black**
Code **GM**



Self-extinguishing Polypropylene
Colour **White**
Code **AU**

DIFFERENT DAMETERS AND MATERIALS AVAILABLE ON REQUEST.

Clamp body internal surface:
profiled

For Material Characteristics, see Technical Appendix (page 147).

COMPONENTS AND ACCESSORIES STANDARD MATERIALS

Carbon Steel S 235 JR with finishing surface in white zinc-coated
Fe Zn c8 II.
Untreated are available on request.

Stainless Steel Inox 316L (X2 CrNiMo 17-12-2) 1.4404
marked with **X** identification code.

Metric thread: code **M**
UNC thread: code **UNC**.

For Material Characteristics, see Technical Appendix (page 147).





S CLAMP BODY

TWO CLAMP HALVES

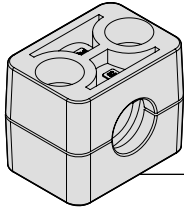

TYPE 2

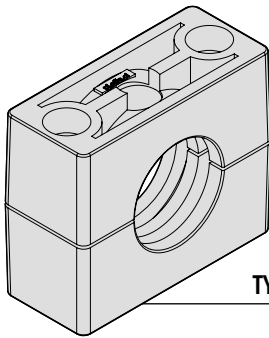

TYPE 3

Code	O.D. ØD1		L1	L2	L3	H	S	Width
	mm	nominal bore pipe						
	8							
	10	1/8"						
	12							
S2	14		43	26	...	33	0,8	30
	15		(1.69")	(1.02")		(1.30")	(.04")	(1.18")
	16							
	17,2	3/8"						
	18							
	20							
	21,3	1/2"						
	22							
	23							
	25							
	26,9	3/4"						
S3	28		70	52	26	57	1	30
	30		(2.75")	(2.05")	(1.02")	(2.24")	(.04")	(1.18")
	32							
	33,7	1"						
	35							
	38							
	40							
	42,4	1.1/4"						

PIPE CLAMPS
SPECIAL SERIES

72

Code S (Material PP - PA - GM - AU)

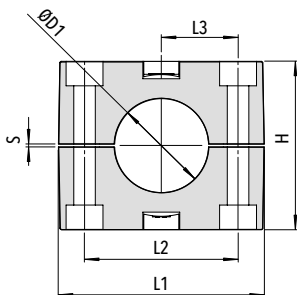
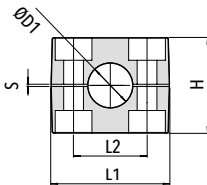

ORDER CODE

CLAMP BODY CODE	OUTSIDE DIAMETER (mm)	MATERIAL
-----------------------	-----------------------------	----------

EXAMPLE

Clamp body type: 2
Material: PP
Outside diameter: 15 mm
Order code: **S2 - 15 - PP**



PP SINGLE WELD PLATE

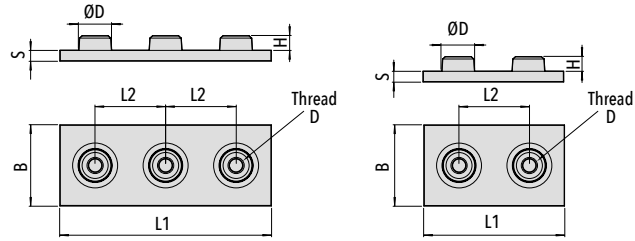

Code	L1	L2	B	S	H	ØD	Thread D
------	----	----	---	---	---	----	----------

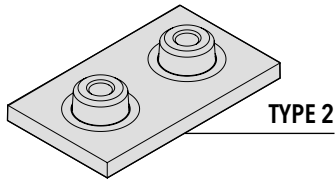

PP2 XPP2	52 (2.05")	26 (1.02")	30 (1.18")	4 (.16")	5,5 (.22")	12 (.47")	M6 (1/4-20 UNC)
---------------------------	---------------	---------------	---------------	-------------	---------------	--------------	--------------------

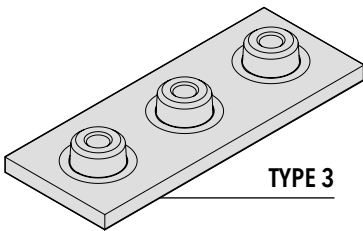

PP3 XPP3	78 (3.07")	26 (1.02")	30 (1.18")	4 (.16")	5,5 (.22")	12 (.47")	M6 (1/4-20 UNC)
---------------------------	---------------	---------------	---------------	-------------	---------------	--------------	--------------------

Code **PP** (Carbon Steel S 235 JR)
Code **XPP** (Stainless Steel AISI 316L).

PIPE CLAMPS
SPECIAL SERIES

PA ANGLED SINGLE WELD PLATE

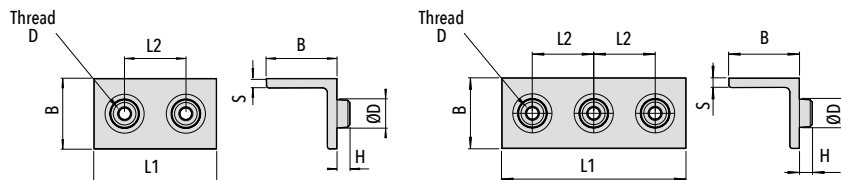

Code	L1	L2	B	S	H	ØD	Thread D
------	----	----	---	---	---	----	----------

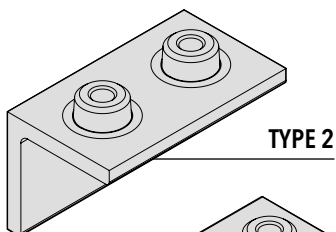

PA2 XPA2	52 (2.05")	26 (1.02")	30 (1.18")	4 (.16")	5,5 (.22")	12 (.47")	M6 (1/4-20 UNC)
---------------------------	---------------	---------------	---------------	-------------	---------------	--------------	--------------------

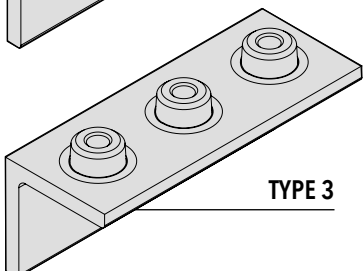

PA3 XPA3	78 (3.07")	26 (1.02")	30 (1.18")	4 (.16")	5,5 (.22")	12 (.47")	M6 (1/4-20 UNC)
---------------------------	---------------	---------------	---------------	-------------	---------------	--------------	--------------------

Code **PA** (Carbon Steel S 235 JR)
Code **XPA** (Stainless Steel AISI 316L).



PPM MULTIPLE WELD PLATE

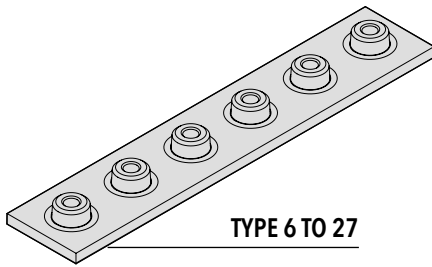
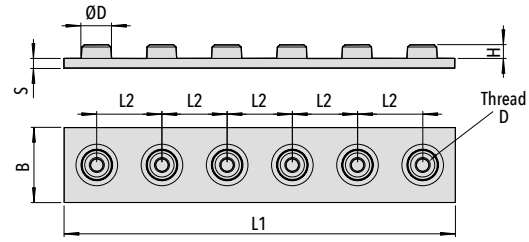

TYPE 6 TO 27

Code	L1	L2	B	S	H	ØD	Thread D
PPM5 XPPM5	130 (5.12")	26 (1.02")	30 (1.18")	4 (.16")	6 (.23")	12 (.47")	M6 (1/4-20 UNC)
PPM6 XPPM6	156 (6.14")	26 (1.02")	30 (1.18")	4 (.16")	6 (.23")	12 (.47")	M6 (1/4-20 UNC)
PPM7 XPPM7	182 (7.17")	26 (1.02")	30 (1.18")	4 (.16")	6 (.23")	12 (.47")	M6 (1/4-20 UNC)
PPM9 XPPM9	234 (9.21")	26 (1.02")	30 (1.18")	4 (.16")	6 (.23")	12 (.47")	M6 (1/4-20 UNC)
PPM12 XPPM12	312 (12.28")	26 (1.02")	30 (1.18")	4 (.16")	6 (.23")	12 (.47")	M6 (1/4-20 UNC)
PPM15 XPPM15	390 (15.35")	26 (1.02")	30 (1.18")	4 (.16")	6 (.23")	12 (.47")	M6 (1/4-20 UNC)
PPM20 XPPM20	520 (20.47")	26 (1.02")	30 (1.18")	4 (.16")	6 (.23")	12 (.47")	M6 (1/4-20 UNC)
PPM27 XPPM27	702 (27.63")	26 (1.02")	30 (1.18")	4 (.16")	6 (.23")	12 (.47")	M6 (1/4-20 UNC)

Code PPM (Carbon Steel S 235 JR)
Code XPPM (Stainless Steel AISI 316L).

PIPE CLAMPS
SPECIAL SERIES

74

PAM ANGLED MULTIPLE WELD PLATE

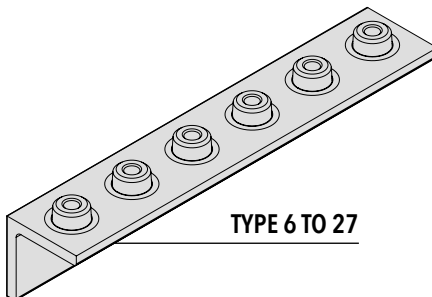
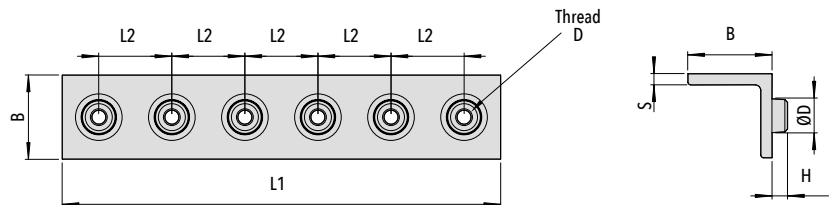

TYPE 6 TO 27

Code	L1	L2	B	S	H	ØD	Thread D
PAM5 XPAM5	130 (5.12")	26 (1.02")	30 (1.18")	4 (.16")	6 (.23")	12 (.47")	M6 (1/4-20 UNC)
PAM6 XPAM6	156 (6.14")	26 (1.02")	30 (1.18")	4 (.16")	6 (.23")	12 (.47")	M6 (1/4-20 UNC)
PAM7 XPAM7	182 (7.17")	26 (1.02")	30 (1.18")	4 (.16")	6 (.23")	12 (.47")	M6 (1/4-20 UNC)
PAM9 XPAM9	234 (9.21")	26 (1.02")	30 (1.18")	4 (.16")	6 (.23")	12 (.47")	M6 (1/4-20 UNC)
PAM12 XPAM12	312 (12.28")	26 (1.02")	30 (1.18")	4 (.16")	6 (.23")	12 (.47")	M6 (1/4-20 UNC)
PAM15 XPAM15	390 (15.35")	26 (1.02")	30 (1.18")	4 (.16")	6 (.23")	12 (.47")	M6 (1/4-20 UNC)
PAM20 XPAM20	520 (20.47")	26 (1.02")	30 (1.18")	4 (.16")	6 (.23")	12 (.47")	M6 (1/4-20 UNC)
PAM27 XPAM27	702 (27.63")	26 (1.02")	30 (1.18")	4 (.16")	6 (.23")	12 (.47")	M6 (1/4-20 UNC)

Code PAM (Carbon Steel S 235 JR)
Code XPAM (Stainless Steel AISI 316L).



PS UPPER PLATE

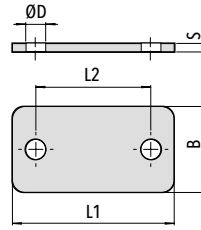

Code	L1	L2	B	S	ØD
------	----	----	---	---	----

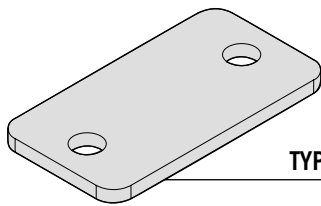

TYPE 3,6

PS3 XPS3	40,5 (1.59")	26 (1.02")	30 (1.18")	3 (.12")	7 (.28")
---------------------------	-----------------	---------------	---------------	-------------	-------------

PS6 XPS6	69,5 (2.74")	52 (2.05")	30 (1.18")	3 (.12")	7 (.28")
---------------------------	-----------------	---------------	---------------	-------------	-------------

Code PS (Carbon Steel S 235 JR)
Code XPS (Stainless Steel AISI 316L)

PIPE CLAMPS
SPECIAL SERIES

VE HEXAGON HEAD BOLT

ISO 4014 / 4017
FOR USE WITH UPPER PLATE PS

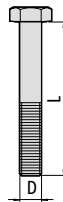

Code	Thread (D x L)
------	-------------------

VE3 XVE3	M6x35 (1/4-20 UNCx1.3/8")
---------------------------	------------------------------

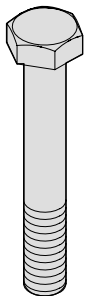

VE6 XVE6	M6x60 (1/4-20 UNCx2.3/8")
---------------------------	------------------------------

Code VE (Steel 8.8)
Code XVE (Stainless Steel A4)

TCEI SOCKET CAP SCREW

ISO 4762

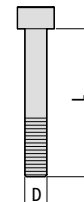

Code	Thread (D x L)
------	-------------------

TCEI3 XTCEI3	M6x25 (1/4-20 UNCx1")
-------------------------------	--------------------------

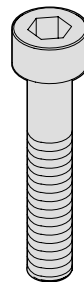

TCEI6 XTCEI6	M6x50 (1/4-20 UNCx2")
-------------------------------	--------------------------

Code TCEI (Steel 8.8)
Code XTCEI (Stainless Steel AISI 316L)



RP FLAT WASHER

FOR USE WITH SCREW TCEI

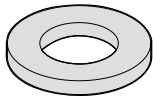
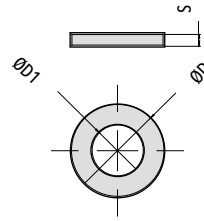

Code	ØD	ØD1	S
RP XRP	11,5 (.45")	6,3 (.25")	0,8 (.03")

Code RP (Carbon Steel S 235 JR)**Code XRP** (Stainless Steel AISI 316L)



MOUNTING EXAMPLE 01

Mounting Example of complete clamp S2 in Polypropylene for pipe with outside diameter of 18 mm, with single weld plate.

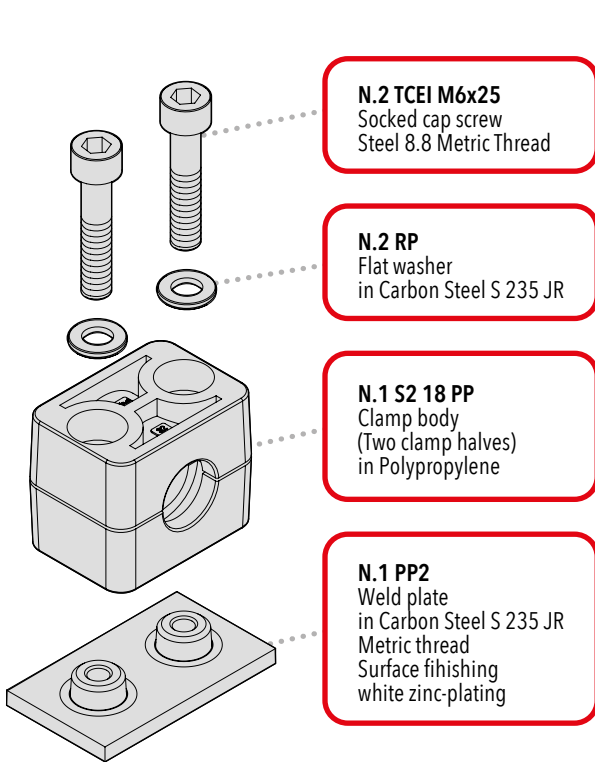

N.2 TCEI M6x25
Socketed cap screw
Steel 8.8 Metric Thread

N.2 RP
Flat washer
in Carbon Steel S 235 JR

N.1 S2 18 PP
Clamp body
(Two clamp halves)
in Polypropylene

N.1 PP2
Weld plate
in Carbon Steel S 235 JR
Metric thread
Surface finishing
white zinc-plating

MOUNTING EXAMPLE 02

Mounting Example of complete clamp S3 in Polyamide for pipe with outside diameter of 30 mm, with angled single weld plate.

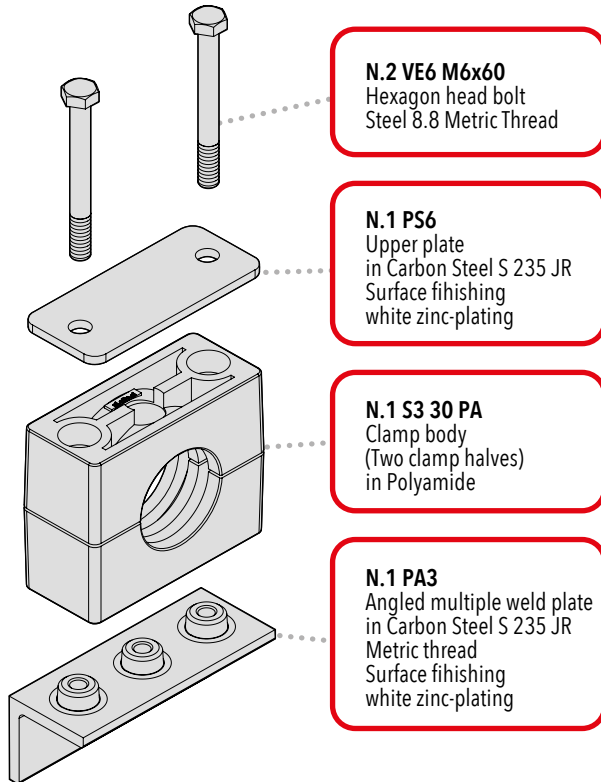

N.2 VE6 M6x60
Hexagon head bolt
Steel 8.8 Metric Thread

N.1 PS6
Upper plate
in Carbon Steel S 235 JR
Surface finishing
white zinc-plating

N.1 S3 30 PA
Clamp body
(Two clamp halves)
in Polyamide

N.1 PA3
Angled multiple weld plate
in Carbon Steel S 235 JR
Metric thread
Surface finishing
white zinc-plating

PIPE CLAMPS
SPECIAL SERIES

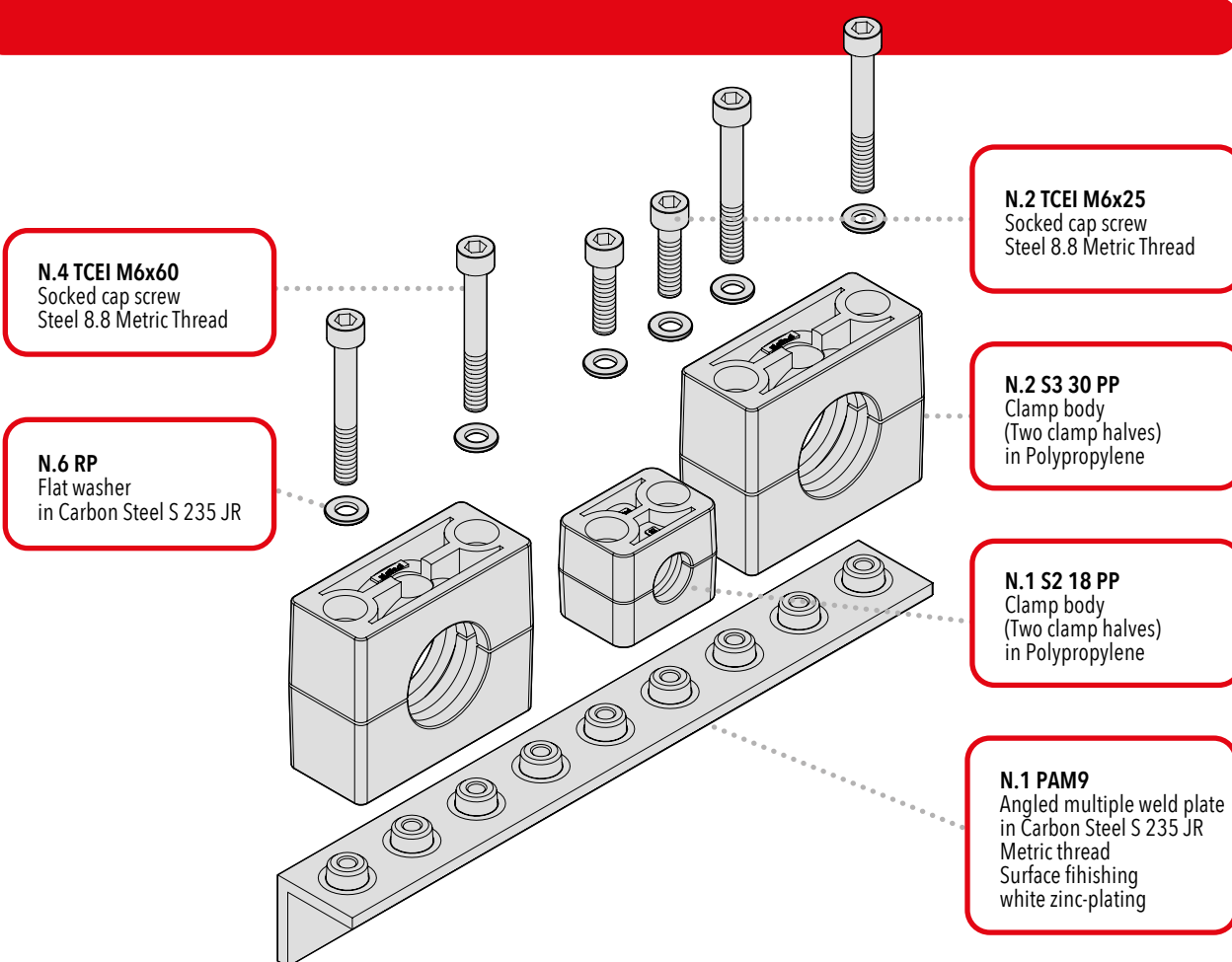

N.4 TCEI M6x60
Socketed cap screw
Steel 8.8 Metric Thread

N.6 RP
Flat washer
in Carbon Steel S 235 JR

N.2 TCEI M6x25
Socketed cap screw
Steel 8.8 Metric Thread

N.2 S3 30 PP
Clamp body
(Two clamp halves)
in Polypropylene

N.1 S2 18 PP
Clamp body
(Two clamp halves)
in Polypropylene

N.1 PAM9
Angled multiple weld plate
in Carbon Steel S 235 JR
Metric thread
Surface finishing
white zinc-plating