

POMPE A PISTONI FISSAGGIO 4 FORI-ISO

CODICE FAMIGLIA
FAMILY CODE

108-005

4 HOLES-ISO HYDRAULIC PISTON PUMPS

"DARK" ISO

Codice fascicolo: 997-400-60010 Rev: AD



| | | | | | |
|---|--|--------------------------------------|----------|---|------|
| Fluido idraulico Fluid | Minerale o sintetico compatibile con guarnizioni: Mineral or synthetic compatible with the following seals: NBR, FKM, FPM, Nylon | | | | |
| Viscosità cinematica consigliata Kinematic viscosity suggested | T media ambiente (°C) Average ambient temp. (°C) | < -10 | -10 ÷ 10 | 10 ÷ 35 | > 35 |
| | VG (cSt = mm ² /s) | 16 | 22 | 32 | 46 |
| Viscosità cinematica ottimale di esercizio Optimale kinematic viscosity | | VG = 10 cSt ÷ 100 cSt | | | |
| Viscosità cinematica max consentita all'avviamento Max kinematic viscosity suggested at the start-up | | VG = 750 cSt | | | |
| Indice di viscosità consigliato Viscosity index suggested | | VI > 100 | | Temperatura di esercizio Working temperature | |
| | | | | -15°C ÷ 100°C | |
| Grado di filtrazione Oil filtering | | > 200 bar: 10 µm < 200 bar: 25 µm | | | |
| Pres. di aspirazione Inlet pressure | | 0,85 ÷ 2 bar assoluti/absolut | | | |
| Senso di rotazione Pump rotation | | Bidirezionale Bidirectional | | | |
| Verificare che la pompa sia posizionata almeno 100 mm sotto il livello minimo del serbatoio olio. Prima di avviare la pompa effettuare spurgo aria. Verify that pump is, at least, 100 mm under the minimum level of the tank. Before starting the pump bleed the air. | | | | | |

Data: Lunedì 02 settembre 2013

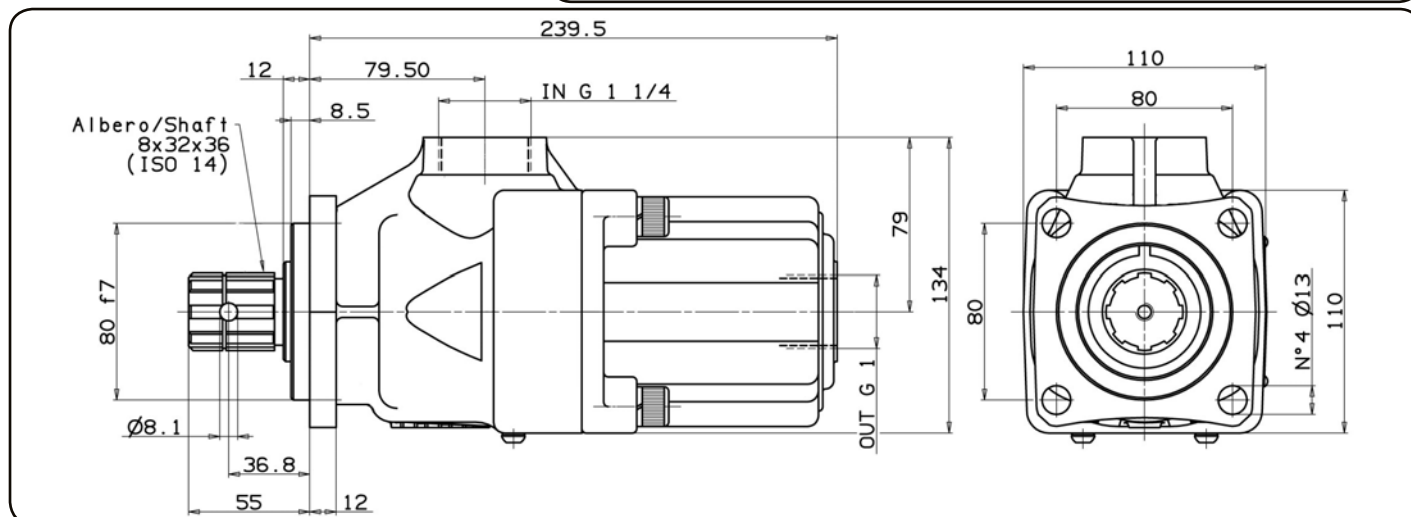

Codice foglio: 997-108-00520 Rev: AG

| Tipo pompa Pump type | Codice Code | Cilindrata Displacement | Pressione Pressure | | Velocità massima Max speed | Peso Weight |
|-------------------------|----------------|----------------------------|-----------------------|---------------|----------------------------------|----------------|
| | | | Massima Max | Picco Peak | | |
| | | cm ³ /rev | bar | bar | rpm | kg |
| DARK-21 | 108-005-02120 | 20,25 | 350 | 400 | 1800 | 14,8 |
| DARK-28 | 108-005-02826 | 27 | | | | 14,5 |
| DARK-35 | 108-005-03521 | 33,75 | | | | 14,4 |
| DARK-42 | 108-005-04226 | 40,5 | | | | 14,3 |
| DARK-48 | 108-005-04824 | 47,25 | | | | 14,2 |
| DARK-52 | 108-005-05225 | 51,97 | | | | 14,2 |
| DARK-55 | 108-005-05529 | 54 | 300 | 350 | 1500 | 14,2 |
| DARK-60 | 108-005-05921 | 59,3 | | | | 14,2 |

pag. 7



O.M.F.B. S.p.A. Hydraulic Components
We reserve the right to make any changes without notice.
Edition 2016.06 No reproduction, however partial, is permitted.
Via Cave, 7/9 25050 Provaglio d'Iseo (Brescia) Italy Tel.: +39.030.9830611
Fax: +39.030.9839207-208 Internet: www.omfb.it e-mail: info@omfb.it

COMPANY WITH
QUALITY SYSTEM
CERTIFIED BY DNV GL
= ISO 9001 =

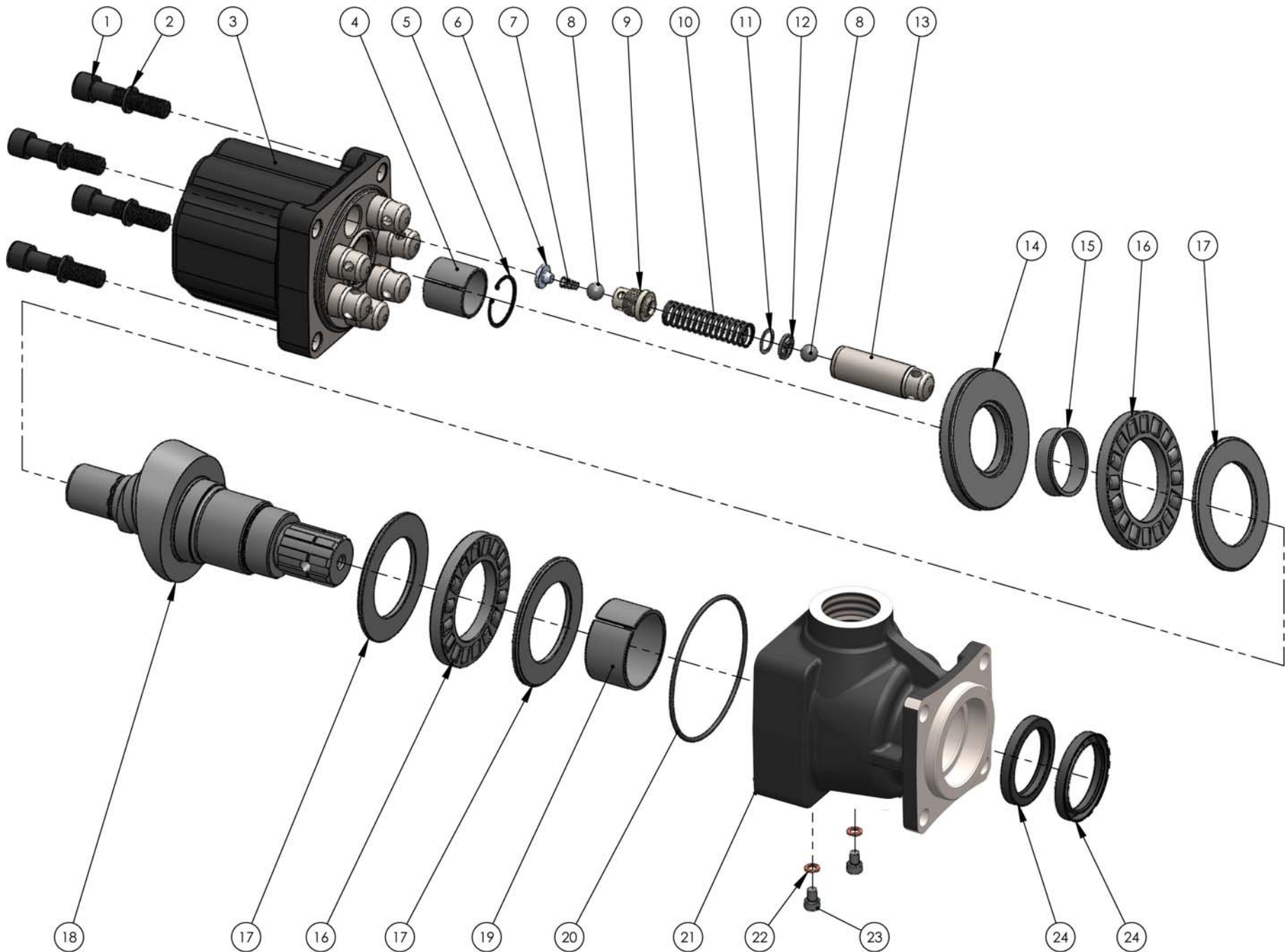

pag. 8

COMPANY WITH
QUALITY SYSTEM
CERTIFIED BY DNV GL
= ISO 9001 =

O.M.F.B. S.p.A. Hydraulic Components
We reserve the right to make any changes without notice.
Edition 2016.06 No reproduction, however partial, is permitted.
Via Cava, 7/9 25050 Proseggio d'Iso (Brescia) Italy Tel.: +39 030.9830611
Fax: +39 030.9839207-208 Internet: www.omfb.it e-mail: info@omfb.it

OMFB
HYDRAULIC COMPONENTS

| N° N° | 21 | 28 | 35 | 42 | 48 | 52 | 55 | 60 | Codice P. Number | Descrizione Description | | Quantità Quantity |
|----------|------|------|-------|-------|-------|-------|-------|-------|---------------------|-------------------------------|----------------------------|----------------------|
| 1 | • | • | • | • | • | • | • | • | 502-005-00591 | Vite TCE M12x55 UNI 5931 | Socket head capscrew | 4 |
| 2 | • | • | • | • | • | • | • | • | 501-008-00063 | Rondella elastica | Washer | 4 |
| 3 | • | | | | | | | | 517-002-00011 | Corpo posteriore | Rear body | 1 |
| | | • | | | | | | | 517-002-00039 | | | |
| | | | • | | | | | | 517-002-00020 | | | |
| | | | | • | | | | | 517-002-00100 | | | |
| | | | | | • | | | | 517-002-00048 | | | |
| | | | | | | • | | | 517-002-00182 | | | |
| | | | | | | | • | | 517-002-00057 | | | |
| | | | | | | | | • | 517-002-00146 | | | |
| 4 | • | • | • | • | • | • | • | • | 533-004-00051 | Boccola 34x30x30 | Bushing 34x30x30 | 1 |
| 5 | • | • | • | • | • | • | • | • | 501-000-00187 | Anello elastico | Circlip | 1 |
| 6 | • x3 | • x4 | • x5 | • x6 | • x7 | • x7 | • x8 | • x8 | 542-001-00135 | Corpo guida molla | Spring guide body | |
| 7 | • x3 | • x4 | • x5 | • x6 | • x7 | • x7 | • x8 | • x8 | 512-004-00153 | Molla conica | Tapered spring | |
| 8 | • x6 | • x8 | • x10 | • x12 | • x14 | • x14 | • x16 | • x16 | 510-009-00116 | Sfera grano 7/16" | Ball 7/16" | |
| 9 | • x3 | • x4 | • x5 | • x6 | • x7 | • x7 | • x8 | • x8 | 540-000-00149 | Tappo valvola mandata | Plug delivery valve | |
| 10 | • x3 | • x4 | • x5 | • x6 | • x7 | • x7 | • x8 | • x8 | 512-005-01946 | Molla ritorno pistone | Back piston spring | |
| 11 | • x3 | • x4 | • x5 | • x6 | • x7 | • x7 | • x8 | • x8 | 530-000-00159 | Distanziale | Spacer | |
| 12 | • x3 | • x4 | • x5 | • x6 | • x7 | • x7 | • x8 | • x8 | 550-001-00209 | Part. arresto sfera pompanti | Spacer sprine guide | |
| 13 | • x3 | • x4 | • x5 | • x6 | • x7 | | • x8 | | 532-004-00026 | Pistone pompante ø21 | Pump piston ø21 | |
| | | | | | | • x7 | | • x8 | 532-004-00035 | Pistone pompante ø22 | Pump piston ø22 | |
| 14 | • | • | • | • | • | • | • | • | 510-006-00379 | Ralla 93x44x10.4 | Bearing 93x44x10.4 | 1 |
| 15 | • | • | • | • | • | • | • | • | 533-004-00159 | Boccola 40x44x12 | Bushing 40x44x12 | 1 |
| 16 | • | • | • | • | • | • | • | • | 510-006-55909 | Gabbia assiale rulli 92x55x11 | Axial roller cage 92x55x11 | 2 |
| 17 | • | • | • | • | • | • | • | • | 510-006-00431 | Ralla 88x55x4 | Bearing 88x55x4 | 3 |
| 18 | • | • | • | • | • | • | • | • | 522-005-00115 | Albero | Shaft | 1 |
| 19 | • | • | • | • | • | • | • | • | 533-004-00168 | Boccola 55x50x30 | Bushing 55x50x30 | 1 |
| 20 | • | • | • | • | • | • | • | • | 506-002-00630 | Guarnizione OR | O-Ring | 1 |
| 21 | • | • | • | • | • | • | • | • | 517-002-00315 | Corpo anteriore | Front housing | 1 |
| 22 | • | • | • | • | • | • | • | • | 116-009-01022 | Rondella rame 10x6x1 | Washer | 2 |
| 23 | • | • | • | • | • | • | • | • | 502-000-01120 | Vite TCE M6x8 | Socket head capscrew | 2 |
| 24 | • | • | • | • | • | • | • | • | 506-007-00706 | Paraolio | Oil seal | 2 |

PORTATA
FLOW

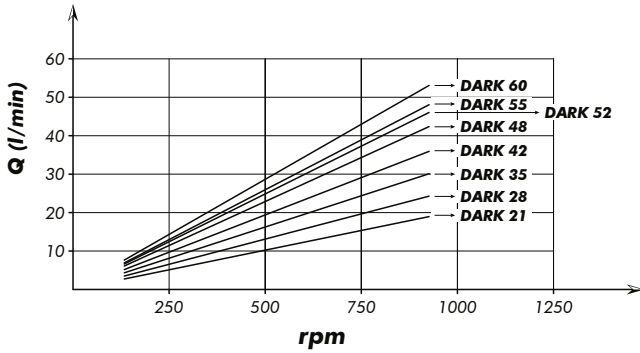

COPPIA ASSORBITA
DRIVE TORQUE

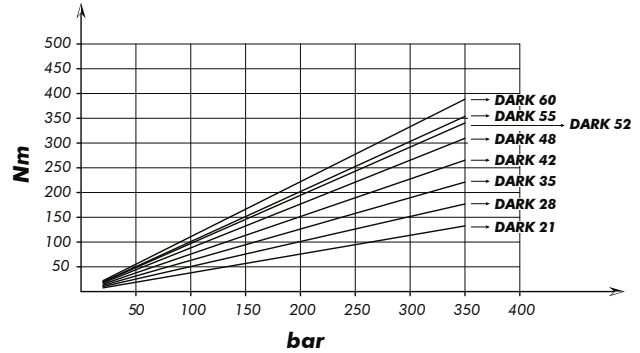

POTENZA ASSORBITA
POWER INPUT

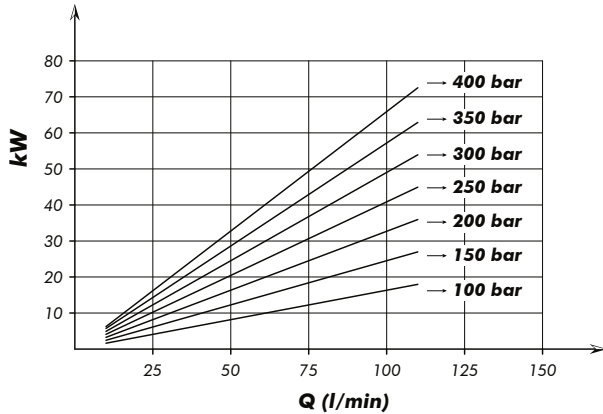

MOMENTO PESO / MASS MOMENT

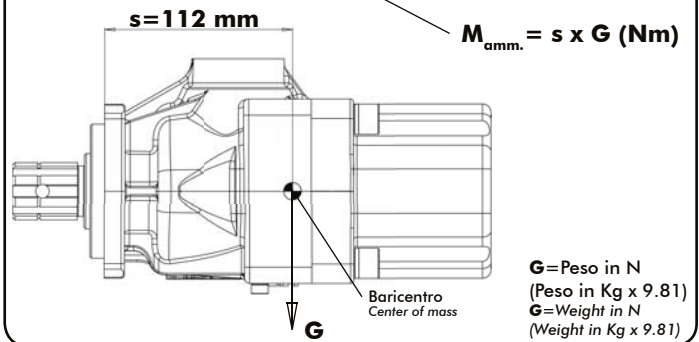

La quota "s" può essere considerata unica per tutte le cilindrate.
"s" dimension can be considered valid for all pump displacement.

Kit guarnizioni
Seal Kit

108-903-00027