

# LMC®

## AĞIR SERİ HEAVY SERIES

DIN 3015 / 2

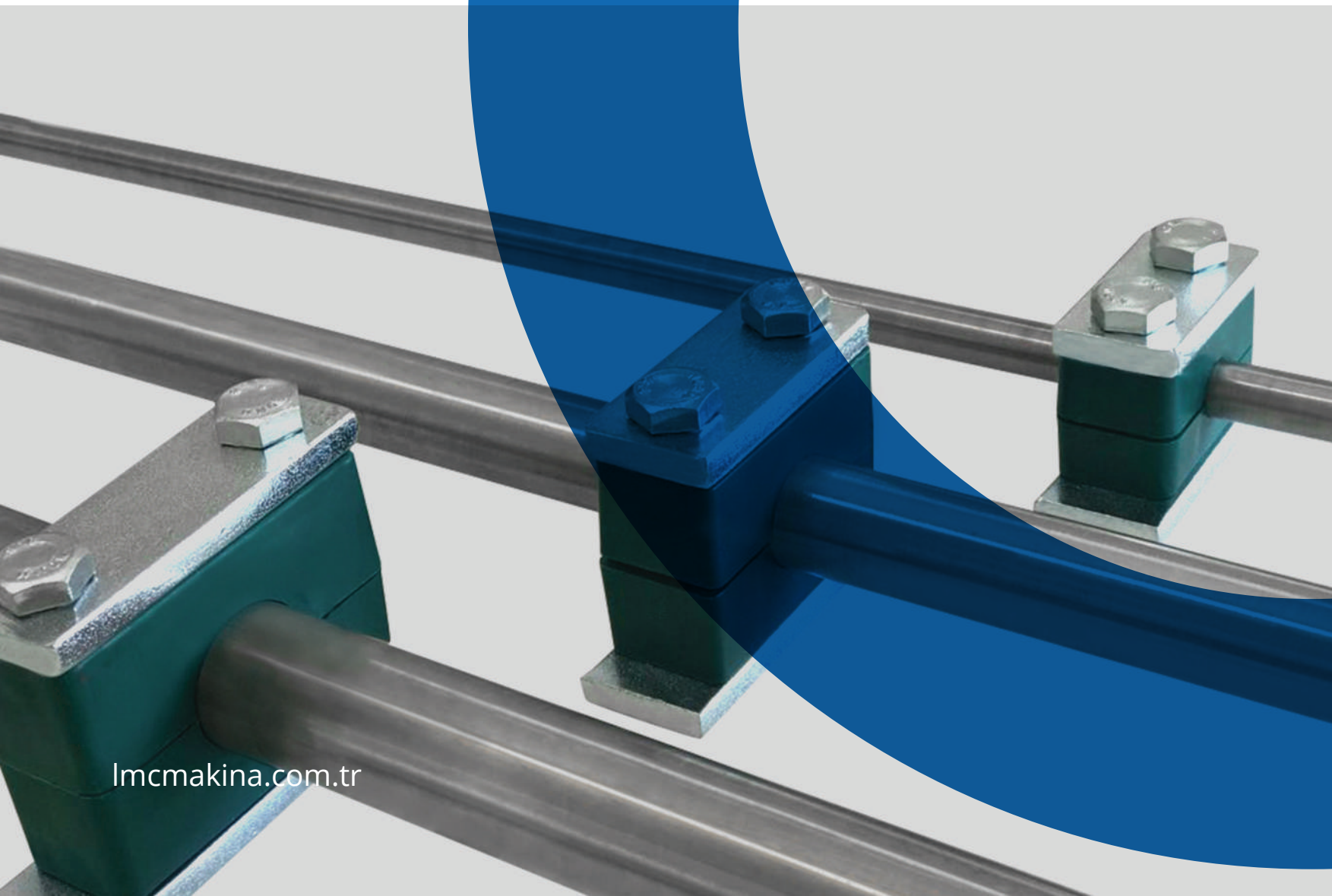
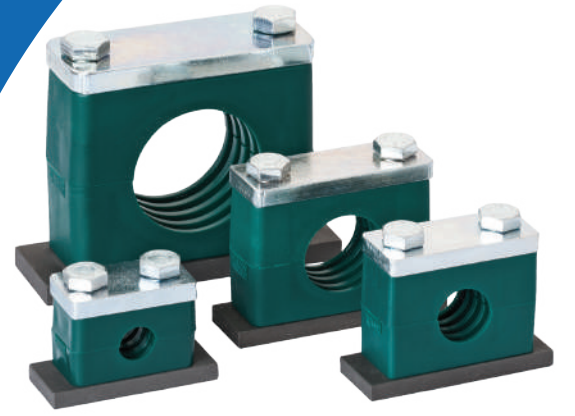

[lmcmakina.com.tr](http://lmcmakina.com.tr)

Metal + Kaplama Tipi Metal + Surface Finishing		Gövde Malzemesi Clamp Body Material	
0	Kaplanmasız / Uncoated	A	Alüminyum / Aluminum
1	Fosfat / Phosphated / Fe/Znph	N	Polyamid / Polyamide
3	Galvaniz / Galvanized / Fe/Zn 8C Cr3-B	T	TPE
4	CrNi 304 AISI 304	P	Polipropilen / Polypropylene
6	CrNi 316 AISI 316		
9	Çinko Nikel / Zinc Nickel Fe/ZnNi		

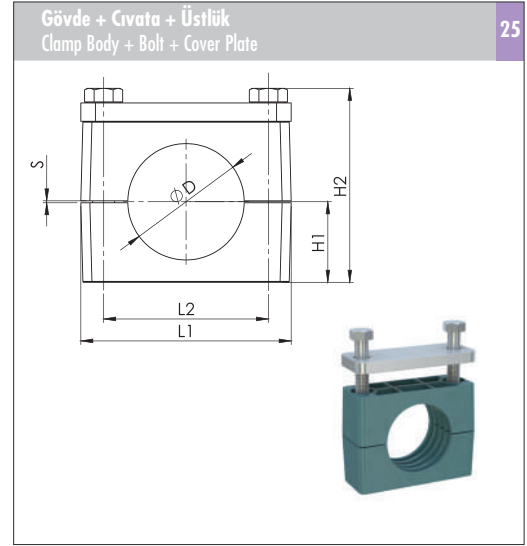
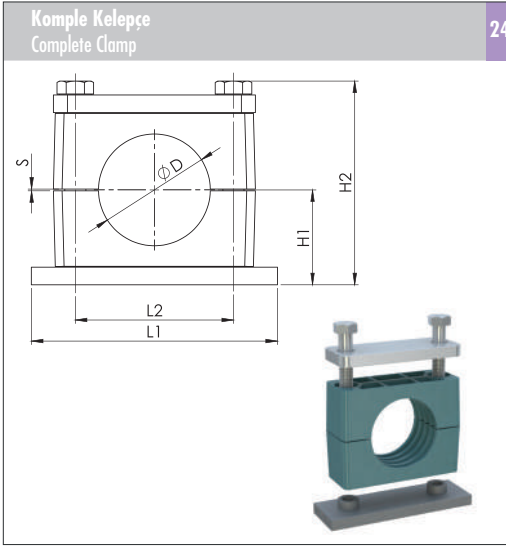

Farklı malzeme talepleriniz için lütfen LMC Makina'ya danışınız.

For different material request please consult LMC Makina.

CM40M11P1YA11X.XX.X

Metal + Kaplama Tipi  
Metal + Surface Finishing  
 Gövde Malzemesi  
Clamp Body Material  
 Gövde Renk  
Clamp Body Colour  
 Grup  
Group  
 Ölçü  
Size

CD68M13P1YA11X.XX.X

Metal + Kaplama Tipi  
Metal + Surface Finishing  
 Gövde Malzemesi  
Clamp Body Material  
 Gövde Renk  
Clamp Body Colour  
 Grup  
Group  
 Ölçü  
Size

Grup	Dış Çap (ØD)	Anma Çapı (R) Boru Diş	Dış Çap (ØD)
Group	O.D. of Pipe / Tube / Hose mm	Nominal Bore Pipe inch	O.D. of Pipe / Tube / Hose inch
A1	6		1/4
	6.4		5/16
	8		3/8
	9.5	R 1/8	
	10		
	12		1/2
	12.7	R 1/4	
	13.5		
	14		
	15		5/8
16			
17.2	R 3/8		
18			
A2	19		3/4
	20		
	21.3	R 1/2	
	22		7/8
	25		1
	25.4		
	26.9	R 3/4	
	28		
30			
A3	30		1 1/4
	32		
	33.7	R 1	
	35		1 1/2
	38		
	40		
42	R 1 1/4		
A4	38		1 1/2
	42		
	44.5		1 3/4
	48.3	R 1 1/2	
	50.8		2
	55		
	57		2 1/4
	60.3	R 2	
	63.5		2 1/2
	65		
70		2 3/4	

Ölçü Tablosu						Sipariş Kodu
Dimension Table						
L1	L2	H1	H2	S min.	Genişlik	Width
74	33	24	55	0.6	30	
86	45	32	71	0.6	30	CM40M11P1YA2019.0 CM40M11P1YA2020.0 CM40M11P1YA2021.3 CM40M11P1YA2022.0 CM40M11P1YA2025.0 CM40M11P1YA2025.4 CM40M11P1YA2026.9 CM40M11P1YA2028.0 CM40M11P1YA2030.0
100	60	38	83	0.6	30	CM40M11P1YA3030.0 CM40M11P1YA3032.0 CM40M11P1YA3033.7 CM40M11P1YA3035.0 CM40M11P1YA3038.0 CM40M11P1YA3040.0 CM40M11P1YA3042.0
140	90	54.5	117	2	45	CM40M11P1YA4038.0 CM40M11P1YA4042.0 CM40M11P1YA4044.5 CM40M11P1YA4048.3 CM40M11P1YA4050.8 CM40M11P1YA4055.0 CM40M11P1YA4057.0 CM40M11P1YA4060.3 CM40M11P1YA4063.5 CM40M11P1YA4065.0 CM40M11P1YA4070.0

Ölçü Tablosu						Sipariş Kodu
Dimension Table						
L1	L2	H1	H2	S min.	Genişlik	Width
55	33	16	47	0.6	30	
70	45	24	63	0.6	30	CD68M13P1YA2019.0 CD68M13P1YA2020.0 CD68M13P1YA2021.3 CD68M13P1YA2022.0 CD68M13P1YA2025.0 CD68M13P1YA2025.4 CD68M13P1YA2026.9 CD68M13P1YA2028.0 CD68M13P1YA2030.0
85	60	30	75	0.6	30	CD68M13P1YA3030.0 CD68M13P1YA3032.0 CD68M13P1YA3033.7 CD68M13P1YA3035.0 CD68M13P1YA3038.0 CD68M13P1YA3040.0 CD68M13P1YA3042.0
115	90	44.5	107	2	45	CD68M13P1YA4038.0 CD68M13P1YA4042.0 CD68M13P1YA4044.5 CD68M13P1YA4048.3 CD68M13P1YA4050.8 CD68M13P1YA4055.0 CD68M13P1YA4057.0 CD68M13P1YA4060.3 CD68M13P1YA4063.5 CD68M13P1YA4065.0 CD68M13P1YA4070.0

Metal + Kaplama Tipi Metal + Surface Finishing		Gövde Malzemesi Clamp Body Material	
0	Kaplamasız / Uncoated	A	Alüminyum / Aluminum
1	Fosfat / Phosphated / Fe/Znph	N	Polyamid / Polyamide
3	Galvaniz / Galvanized / Fe/Zn 8C Cr3-B	T	TPE
4	CrNi 304 AISI 304	P	Polipropilene / Polypropylene
6	CrNi 316 AISI 316		
9	Çinko Nikel / Zinc Nickel / Fe/ZnNi		

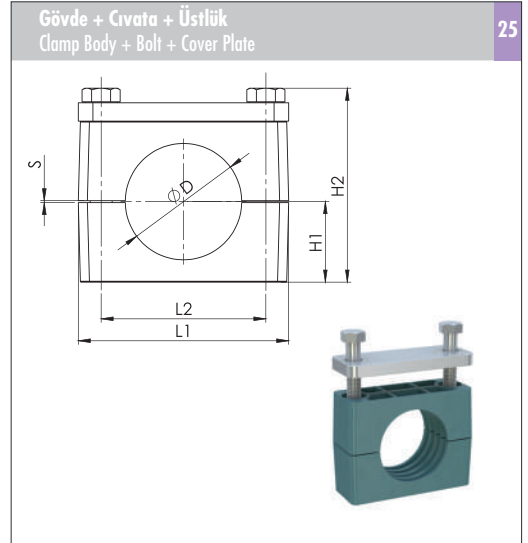
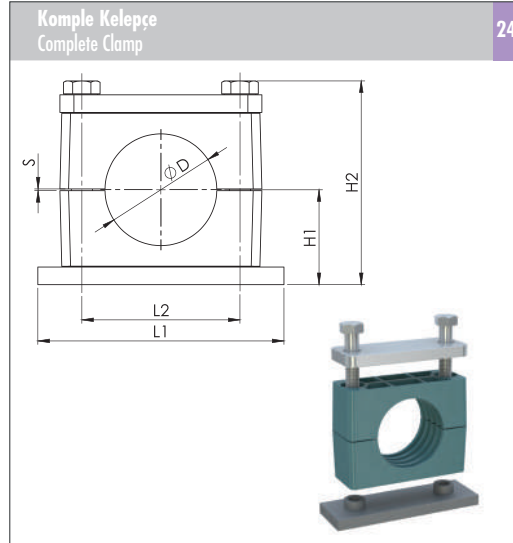

Farklı malzeme talepleriniz için lütfen LMC Makina'ya danışınız.

For different material request please consult LMC Makina.

C M 4 0 M 1 1 P 1 Y A 1 X X X . X

Metal + Kaplama Tipi / Metal + Surface Finishing  
 Gövde Malzemesi / Clamp Body Material  
 Gövde Renk / Clamp Body Colour  
 Grup / Group  
 Ölçü / Size

C D 6 8 M 1 3 P 1 Y A 1 X X X . X

Metal + Kaplama Tipi / Metal + Surface Finishing  
 Gövde Malzemesi / Clamp Body Material  
 Gövde Renk / Clamp Body Colour  
 Grup / Group  
 Ölçü / Size

Grup Group	Dış Çap (ØD) O.D. of Pipe / Tube / Hose mm	Anma Çapı (R) Boru Dış Nominal Bore Pipe inch	Dış Çap (ØD) O.D. of Pipe / Tube / Hose inch
A5	65		
	70		
	73	R 2 1/2	2 7/8
	76.1	R 2 1/2	3
	80		
	82.5		3 1/4
A6	88.9	R 3	3 1/2
	88.9	R 3	3 1/2
	100		
	101.6	R 3 1/2	4 1/4
A7	108		
	114.3	R 4	5
	127		5 1/4
	133		5 1/4
	133		5 1/4
	139.7	R 5	6
A8	152.4		6 1/4
	159		6 1/2
	165		
	168.3	R 6	7
	168.3	R 6	7 5/8
A9	177.8		8 1/2
	193.7		
	216	R 8	
	219.1	R 8	
A10	219.1	R 8	
	244.5		
	273	R 10	
A10	323.9	R 12	
	355.6	R 14	
	406.4	R 16	

**Ölçü Tablosu**  
Dimension Table

L1	L2	H1	H2	S min.	Genişlik Width	Sipariş Kodu Order Code
180	122	70	150	2	60	CM40M11P1YA5065.0 CM40M11P1YA5070.0 CM40M11P1YA5073.0 CM40M11P1YA5076.1 CM40M11P1YA5080.0 CM40M11P1YA5082.5 CM40M11P1YA5088.9
226	168	99	211	2	80	CM40M11P1YA6088.9 CM40M11P1YA6100.0 CM40M11P1YA6101.6 CM40M11P1YA6108.0 CM40M11P1YA6114.3 CM40M11P1YA6127.0 CM40M11P1YA6133.0
270	205	115	245	3	90	CM40M11P1YA7133.0 CM40M11P1YA7139.7 CM40M11P1YA7152.4 CM40M11P1YA7159.0 CM40M11P1YA7165.0 CM40M11P1YA7168.3
340	265	160	339	3	120	CM40M11P1YA8168.3 CM40M11P1YA8177.8 CM40M11P1YA8193.7 CM40M11P1YA8216.0 CM40M11P1YA8219.1
520	395	235	489	8	160	CM40M11P1YA9219.1 CM40M11P1YA9244.5 CM40M11P1YA9273.0 CM40M11P1YA9323.9
680	534	295	609	18	180	CM40M11P1YA0355.6 CM40M11P1YA0406.4

**Ölçü Tablosu**  
Dimension Table

L1	L2	H1	H2	S	Genişlik Width	Sipariş Kodu Order Code
154	122	60	140	2	60	CD68M13P1YA5065.0 CD68M13P1YA5070.0 CD68M13P1YA5073.0 CD68M13P1YA5076.1 CD68M13P1YA5080.0 CD68M13P1YA5082.5 CD68M13P1YA5088.9
206	168	84	196	2	80	CD68M13P1YA6088.9 CD68M13P1YA6100.0 CD68M13P1YA6101.6 CD68M13P1YA6108.0 CD68M13P1YA6114.3 CD68M13P1YA6127.0 CD68M13P1YA6133.0
251	205	100	230	3	90	CD68M13P1YA7133.0 CD68M13P1YA7139.7 CD68M13P1YA7152.4 CD68M13P1YA7159.0 CD68M13P1YA7165.0 CD68M13P1YA7168.3
335	265	135	314	3	120	CD68M13P1YA8168.3 CD68M13P1YA8177.8 CD68M13P1YA8193.7 CD68M13P1YA8216.0 CD68M13P1YA8219.0
470	395	205	459	8	160	CD68M13P1YA9219.0 CD68M13P1YA9244.5 CD68M13P1YA9273.0 CD68M13P1YA9323.9
630	534	265	579	18	180	CD68M13P1YA0355.6 CD68M13P1YA0406.4

Metal + Kaplama Tipi Metal + Surface Finishing		Gövde Malzemesi Clamp Body Material	
0	Kaplamasız / Uncoated	A	Alüminyum / Aluminum
1	Fosfat / Phosphated / Fe/Znph	N	Polyamid / Polyamide
3	Galvaniz / Galvanized / Fe/Zn 8C Cr3-B	T	TPE
4	CrNi 304 AISI 304	P	Polipropilen / Polypropylene
6	CrNi 316 AISI 316		
9	Çinko Nikel / Zinc Nickel Fe/ZnNi		

Farklı malzeme talepleriniz için lütfen LMC Makina'ya danışınız.

For different material request please consult LMC Makina.

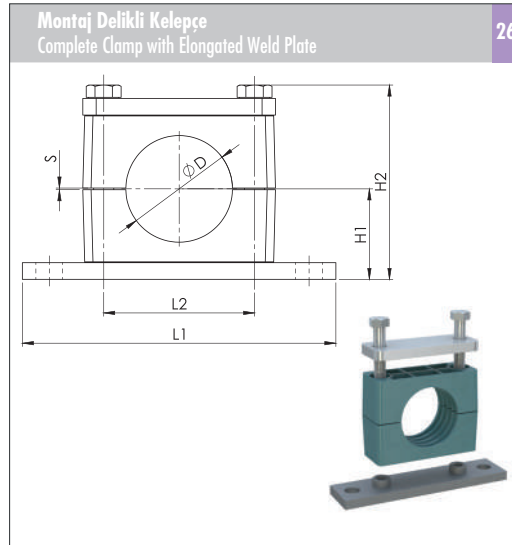

CM	4	1	M	1	1	P	1	Y	A	1	X	X	X	.X

Metal + Kaplama Tipi  
Metal + Surface Finishing  
 Gövde Malzemesi  
Clamp Body Material  
 Gövde Renk  
Clamp Body Colour  
 Grup  
Group  
 Ölçü Site

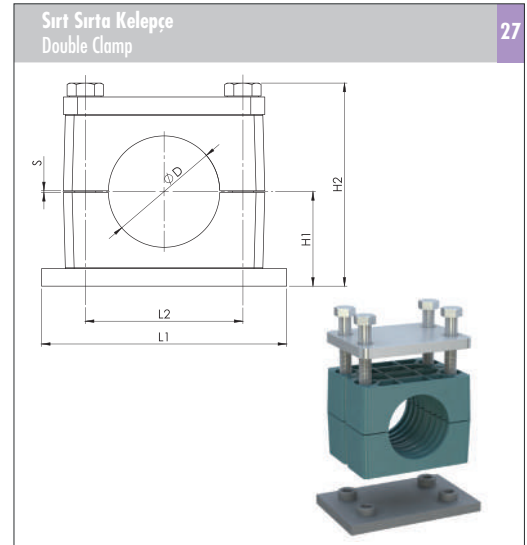

CM	6	0	M	1	1	P	1	Y	A	1	X	X	X	.X

Metal + Kaplama Tipi  
Metal + Surface Finishing  
 Gövde Malzemesi  
Clamp Body Material  
 Gövde Renk  
Clamp Body Colour  
 Grup  
Group  
 Ölçü Site

Grup	Dış Çap (ØD)	Anma Çapı (R) Boru Dış	Dış Çap (ØD)
Group	O.D. of Pipe / Tube / Hose mm	Nominal Bore Pipe inch	O.D. of Pipe / Tube / Hose inch
A1	6		
	6.4		1/4
	8		5/16
	9.5		3/8
	10	R 1/8	
	12		
	12.7		1/2
	13.5	R 1/4	
	14		
	15		
A2	16		5/8
	17.2	R 3/8	
	18		
	19		3/4
	20		
	21.3	R 1/2	
	22		7/8
	25		
A3	25.4		1
	26.9	R 3/4	
	28		
	30		
	30		
	32		1 1/4
	33.7	R 1	
A4	35		
	38		1 1/2
	40		
	42	R 1 1/4	
	38		1 1/2
	42		
	44.5		1 3/4
	48.3	R 1 1/2	
	50.8		2
	55		
57		2 1/4	
60.3	R 2		
63.5		2 1/2	
65			
70		2 3/4	

Ölçü Tablosu							Sipariş Kodu
Dimension Table							Order Code
L1	L2	H1	H2	S min.	Genişlik Width		
113	33	24	55	0.6	30	CM41M11P1YA1006.0	
						CM41M11P1YA1006.4	
						CM41M11P1YA1008.0	
						CM41M11P1YA1009.5	
						CM41M11P1YA1010.0	
						CM41M11P1YA1012.0	
						CM41M11P1YA1012.7	
						CM41M11P1YA1013.5	
						CM41M11P1YA1014.0	
						CM41M11P1YA1015.0	
						CM41M11P1YA1016.0	
						CM41M11P1YA1017.2	
						CM41M11P1YA1018.0	
						CM41M11P1YA2019.0	
						CM41M11P1YA2020.0	
						CM41M11P1YA2021.3	
						CM41M11P1YA2022.0	
						CM41M11P1YA2025.0	
						CM41M11P1YA2025.4	
						CM41M11P1YA2026.9	
						CM41M11P1YA2028.0	
						CM41M11P1YA2030.0	
						CM41M11P1YA3030.0	
						CM41M11P1YA3032.0	
						CM41M11P1YA3033.7	
						CM41M11P1YA3035.0	
						CM41M11P1YA3038.0	
						CM41M11P1YA3040.0	
						CM41M11P1YA3042.0	
						CM41M11P1YA4038.0	
						CM41M11P1YA4042.0	
						CM41M11P1YA4044.5	
						CM41M11P1YA4048.3	
						CM41M11P1YA4050.8	
						CM41M11P1YA4055.0	
						CM41M11P1YA4057.0	
						CM41M11P1YA4060.3	
						CM41M11P1YA4063.5	
						CM41M11P1YA4065.0	
						CM41M11P1YA4070.0	

Ölçü Tablosu							Sipariş Kodu
Dimension Table							Order Code
L1	L2	H1	H2	S min.	Genişlik Width		
74	33	24	55	0.6	60	CM60M11P1YA1006.0	
						CM60M11P1YA1006.4	
						CM60M11P1YA1008.0	
						CM60M11P1YA1009.5	
						CM60M11P1YA1010.0	
						CM60M11P1YA1012.0	
						CM60M11P1YA1012.7	
						CM60M11P1YA1013.5	
						CM60M11P1YA1014.0	
						CM60M11P1YA1015.0	
						CM60M11P1YA1016.0	
						CM60M11P1YA1017.2	
						CM60M11P1YA1018.0	
						CM60M11P1YA2019.0	
						CM60M11P1YA2020.0	
						CM60M11P1YA2021.3	
						CM60M11P1YA2022.0	
						CM60M11P1YA2025.0	
						CM60M11P1YA2025.4	
						CM60M11P1YA2026.9	
						CM60M11P1YA2028.0	
						CM60M11P1YA2030.0	
						CM60M11P1YA3030.0	
						CM60M11P1YA3032.0	
						CM60M11P1YA3033.7	
						CM60M11P1YA3035.0	
						CM60M11P1YA3038.0	
						CM60M11P1YA3040.0	
						CM60M11P1YA3042.0	
						CM60M11P1YA4038.0	
						CM60M11P1YA4042.0	
						CM60M11P1YA4044.5	
						CM60M11P1YA4048.3	
						CM60M11P1YA4050.8	
						CM60M11P1YA4055.0	
						CM60M11P1YA4057.0	
						CM60M11P1YA4060.3	
						CM60M11P1YA4063.5	
						CM60M11P1YA4065.0	
						CM60M11P1YA4070.0	

Metal + Kaplama Tipi Metal + Surface Finishing		Gövde Malzemesi Clamp Body Material	
0	Kaplamasız / Uncoated	A	Alüminyum / Aluminum
1	Fosfat / Phosphated / Fe/Znph	N	Polyamid / Polyamide
3	Galvaniz / Galvanized / Fe/Zn 8C Cr3-B	T	TPE
4	CrNi 304 AISI 304	P	Polipropilen / Polypropylene
6	CrNi 316 AISI 316		
9	Çinko Nikel / Zinc Nickel Fe/ZnNi		

Farklı malzeme talepleriniz için lütfen  
LMC Makina'ya danışınız.

For different material request please consult LMC  
Makina.

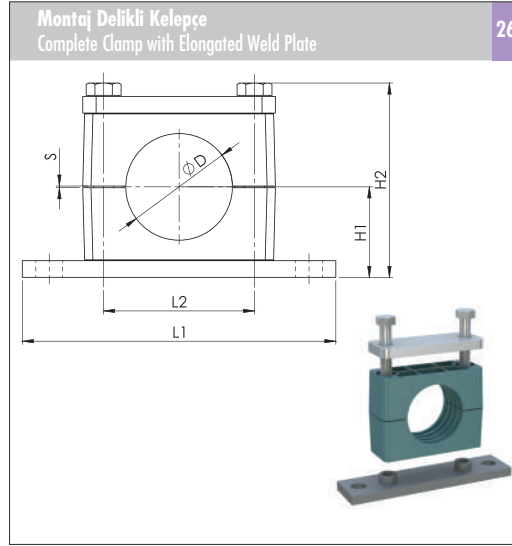

CM	4	1	M	1	P	1	Y	A	1	X	X	X	.	X

Metal + Kaplama Tipi / Metal + Surface Finishing  
 Gövde Malzemesi / Clamp Body Material  
 Gövde Renk / Clamp Body Colour  
 Grup / Group  
 Ölçü / Size

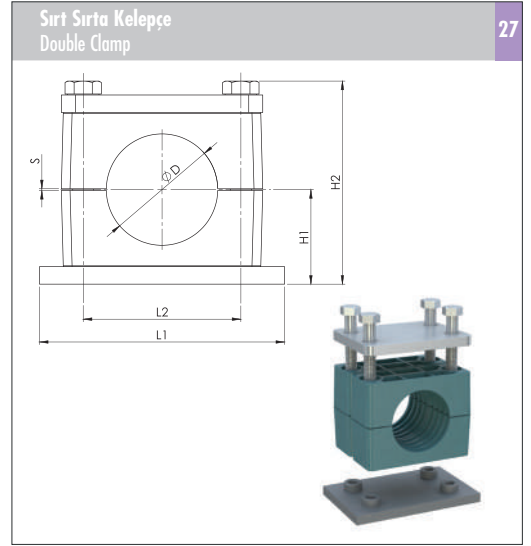

CM	6	0	M	1	P	1	Y	A	1	X	X	X	.	X

Metal + Kaplama Tipi / Metal + Surface Finishing  
 Gövde Malzemesi / Clamp Body Material  
 Gövde Renk / Clamp Body Colour  
 Grup / Group  
 Ölçü / Size

Grup	Dış Çap (ØD)	Anma Çapı (R) Boru Dış	Dış Çap (ØD)
Group	O.D. of Pipe / Tube / Hose mm	Nominal Bore Pipe inch	O.D. of Pipe / Tube / Hose inch
A5	65		
	70		
	73	R 2 1/2	2 7/8
	76.1	R 2 1/2	3
	80		3 1/4
	82.5		3 1/2
A6	88.9	R 3	3 1/2
	88.9	R 3	3 1/2
	100		
	101.6	R 3 1/2	4 1/4
	108		5
	114.3	R 4	5 1/4
A7	127		
	133		
	139.7	R 5	6
	152.4		6 1/4
	159		6 1/2
	165		
A8	168.3	R 6	7
	168.3	R 6	7 5/8
	177.8		8 1/2
	193.7		
	216		
	219.1	R 8	
A9	219.1	R 8	
	244.5		
	273	R 10	
A10	323.9	R 12	
	355.6	R 14	
	406.4	R 16	

Ölçü Tablosu						Sipariş Kodu
Dimension Table						
L1	L2	H1	H2	S min.	Genişlik Width	Order Code
238	122	70	150	2	60	
						CM41M11P1YA5070.0
						CM41M11P1YA5073.0
						CM41M11P1YA5076.1
						CM41M11P1YA5080.0
						CM41M11P1YA5082.5
309	168	99	211	2	80	CM41M11P1YA5088.9
						CM41M11P1YA6088.9
						CM41M11P1YA6100.0
						CM41M11P1YA6101.6
						CM41M11P1YA6108.0
						CM41M11P1YA6114.3
370	205	115	245	3	90	CM41M11P1YA6127.0
						CM41M11P1YA6133.0
						CM41M11P1YA7133.0
						CM41M11P1YA7139.7
						CM41M11P1YA7152.4
						CM41M11P1YA7159.0
440	265	160	339	3	120	CM41M11P1YA7165.0
						CM41M11P1YA7168.3
						CM41M11P1YA8168.3
						CM41M11P1YA8177.8
						CM41M11P1YA8193.7
						CM41M11P1YA8216.0
590	395	235	489	8	160	CM41M11P1YA8219.1
						CM41M11P1YA9219.1
						CM41M11P1YA9244.5
						CM41M11P1YA9273.0
750	534	295	609	18	180	CM41M11P1YA9323.9
						CM41M11P1YA0355.6
						CM41M11P1YA0406.4

Ölçü Tablosu						Sipariş Kodu
Dimension Table						
L1	L2	H1	H2	S min.	Genişlik Width	Order Code
180	122	70	150	2	120	
						CM60M11P1YA5070.0
						CM60M11P1YA5073.0
						CM60M11P1YA5076.1
						CM60M11P1YA5080.0
						CM60M11P1YA5082.5
226	168	99	211	2	160	CM60M11P1YA5088.9
						CM60M11P1YA6088.9
						CM60M11P1YA6100.0
						CM60M11P1YA6101.6
						CM60M11P1YA6108.0
						CM60M11P1YA6114.3
270	205	115	245	3	182	CM60M11P1YA6127.0
						CM60M11P1YA6133.0
						CM60M11P1YA7133.0
						CM60M11P1YA7139.7
						CM60M11P1YA7152.4
						CM60M11P1YA7159.0
340	265	160	339	3	240	CM60M11P1YA7165.0
						CM60M11P1YA7168.3
						CM60M11P1YA8168.3
						CM60M11P1YA8177.8
						CM60M11P1YA8193.7
						CM60M11P1YA8216.0
520	395	235	489	8	324	CM60M11P1YA8219.1
						CM60M11P1YA9219.1
						CM60M11P1YA9244.5
						CM60M11P1YA9273.0
680	534	295	609	18	364	CM60M11P1YA9323.9
						CM60M11P1YA0355.6
						CM60M11P1YA0406.4

Metal + Kaplama Tipi Metal + Surface Finishing		Gövde Malzemesi Clamp Body Material	
0	Kaplanmaz / Uncoated	A	Alüminyum / Aluminum
1	Fosfat / Phosphated / Fe/Znph	N	Polyamid / Polyamide
3	Galvaniz / Galvanized / Fe/Zn 8C Cr3-B	T	TPE
4	CrNi 304 AISI 304	P	Polipropilen / Polypropylene
6	CrNi 316 AISI 316		
9	Çinko Nikel / Zinc Nickel Fe/ZnNi		

Farklı malzeme talepleriniz için lütfen LMC Makina'ya danışınız.

For different material request please consult LMC Makina.

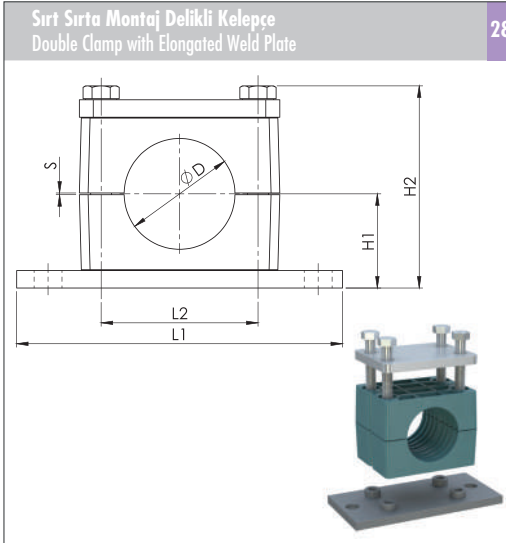

Ç	M	6	1	M	1	P	1	Y	A	1	X	X	X	.	X

Metal + Kaplama Tipi / Metal + Surface Finishing  
 Gövde Malzemesi / Clamp Body Material  
 Kelepçe Renk / Clamp Body Colour  
 Grup / Group  
 Ölçü / Size

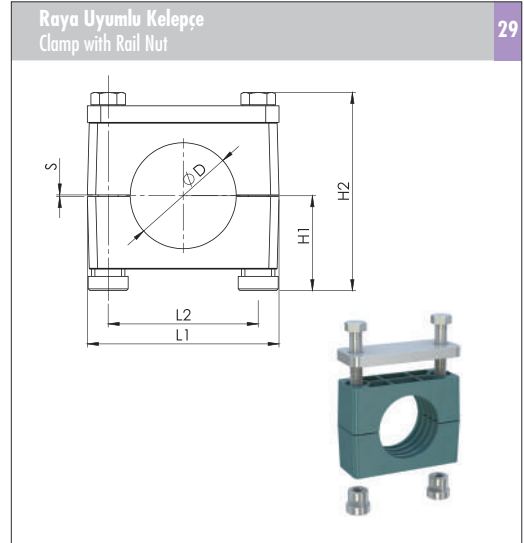

Ç	D	7	0	M	1	3	P	1	Y	A	1	X	X	X	.	X

Metal + Kaplama Tipi / Metal + Surface Finishing  
 Gövde Malzemesi / Clamp Body Material  
 Kelepçe Renk / Clamp Body Colour  
 Grup / Group  
 Ölçü / Size

Grup	Dış Çap (ØD)	Anma Çapı (R) Boru Dış	Dış Çap (ØD)
Group	O.D. of Pipe / Tube / Hose mm	Nominal Bore Pipe inch	O.D. of Pipe / Tube / Hose inch
A1	6		
	6.4		1/4
	8		5/16
	9.5		3/8
	10	R 1/8	
	12		
	12.7		1/2
	13.5	R 1/4	
	14		
	15		
16		5/8	
17.2	R 3/8		
18			
A2	19		3/4
	20		
	21.3	R 1/2	
	22		7/8
	25		
	25.4		1
	26.9	R 3/4	
	28		
	30		
	A3	30	
32			1 1/4
33.7		R 1	
35			
38			1 1/2
40			
42		R 1 1/4	
A4	38		1 1/2
	42		
	44.5		1 3/4
	48.3	R 1 1/2	
	50.8		2
	55		
	57		2 1/4
	60.3	R 2	
	63.5		2 1/2
	65		
70		2 3/4	

Ölçü Tablosu							Sipariş Kodu
Dimension Table							Order Code
L1	L2	H1	H2	S min.	Genişlik		
					Width		
113	33	24	55	0.6	60	CM61M11P1YA1006.0	
						CM61M11P1YA1006.4	
						CM61M11P1YA1008.0	
						CM61M11P1YA1009.5	
						CM61M11P1YA1010.0	
						CM61M11P1YA1012.0	
						CM61M11P1YA1012.7	
						CM61M11P1YA1013.5	
						CM61M11P1YA1014.0	
						CM61M11P1YA1015.0	
						CM61M11P1YA1016.0	
						CM61M11P1YA1017.2	
						CM61M11P1YA1018.0	
						CM61M11P1YA2019.0	
						CM61M11P1YA2020.0	
						CM61M11P1YA2021.3	
						CM61M11P1YA2022.0	
						CM61M11P1YA2025.0	
						CM61M11P1YA2025.4	
						CM61M11P1YA2026.9	
						CM61M11P1YA2028.0	
						CM61M11P1YA2030.0	
						CM61M11P1YA3030.0	
						CM61M11P1YA3032.0	
						CM61M11P1YA3033.7	
						CM61M11P1YA3035.0	
						CM61M11P1YA3038.0	
						CM61M11P1YA3040.0	
						CM61M11P1YA3042.0	
						CM61M11P1YA4038.0	
						CM61M11P1YA4042.0	
						CM61M11P1YA4044.5	
						CM61M11P1YA4048.3	
						CM61M11P1YA4050.8	
						CM61M11P1YA4055.0	
						CM61M11P1YA4057.0	
						CM61M11P1YA4060.3	
						CM61M11P1YA4063.5	
						CM61M11P1YA4065.0	
						CM61M11P1YA4070.0	

Ölçü Tablosu							Sipariş Kodu
Dimension Table							Order Code
L1	L2	H1	H2	S min.	Genişlik		
					Width		
55	33	28.5	59.5	0.6	30	CD70M13P1YA1006.0	
						CD70M13P1YA1006.4	
						CD70M13P1YA1008.0	
						CD70M13P1YA1009.5	
						CD70M13P1YA1010.0	
						CD70M13P1YA1012.0	
						CD70M13P1YA1012.7	
						CD70M13P1YA1013.5	
						CD70M13P1YA1014.0	
						CD70M13P1YA1015.0	
						CD70M13P1YA1016.0	
						CD70M13P1YA1017.2	
						CD70M13P1YA1018.0	
						CD70M13P1YA2019.0	
						CD70M13P1YA2020.0	
						CD70M13P1YA2021.3	
						CD70M13P1YA2022.0	
						CD70M13P1YA2025.0	
						CD70M13P1YA2025.4	
						CD70M13P1YA2026.9	
						CD70M13P1YA2028.0	
						CD70M13P1YA2030.0	
						CD70M13P1YA3030.0	
						CD70M13P1YA3032.0	
						CD70M13P1YA3033.7	
						CD70M13P1YA3035.0	
						CD70M13P1YA3038.0	
						CD70M13P1YA3040.0	
						CD70M13P1YA3042.0	
						CD70M13P1YA4038.0	
						CD70M13P1YA4042.0	
						CD70M13P1YA4044.5	
						CD70M13P1YA4048.3	
						CD70M13P1YA4050.8	
						CD70M13P1YA4055.0	
						CD70M13P1YA4057.0	
						CD70M13P1YA4060.3	
						CD70M13P1YA4063.5	
						CD70M13P1YA4065.0	
						CD70M13P1YA4070.0	

Metal + Kaplama Tipi Metal + Surface Finishing		Gövde Malzemesi Clamp Body Material	
0	Kaplamasız / Uncoated	A	Alüminyum / Aluminum
1	Fosfat / Phosphated / Fe/Znph	N	Polyamid / Polyamide
3	Galvaniz / Galvanized / Fe/Zn 8C Cr3-B	T	TPE
4	CrNi 304 AISI 304	P	Polipropilen / Polypropylene
6	CrNi 316 AISI 316		
9	Çinko Nikel / Zinc Nickel / Fe/ZnNi		

Farklı malzeme talepleriniz için lütfen LMC Makina'ya danışınız.

For different material request please consult LMC Makina.

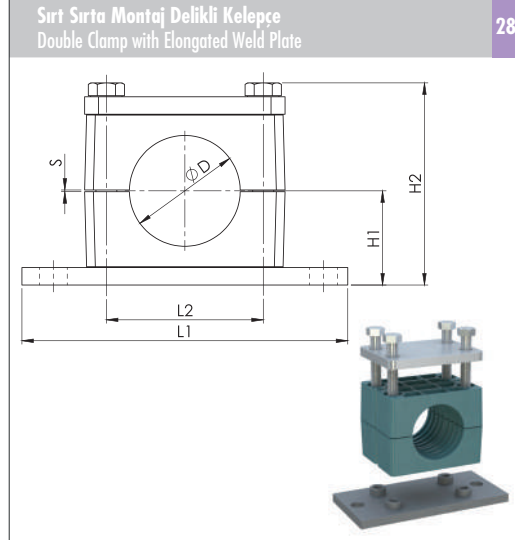

C	M	6	1	M	1	P	1	Y	A	1	X	X	X	.	X

Metal + Kaplama Tipi  
Metal + Surface Finishing  
Gövde Malzemesi  
Clamp Body Material  
 Gövde Renk  
Clamp Body Colour  
 Grup  
Group  
 Ölçü  
Size

Grup Group	Dış Çap (ØD) O.D. of Pipe / Tube / Hose mm	Anma Çapı (R) Boru Dış Nominal Bore Pipe inch	Dış Çap (ØD) O.D. of Pipe / Tube / Hose inch
A5	65		
	70		
	73	R 2 1/2	2 7/8
	76.1	R 2 1/2	3
	80		3 1/4
	82.5		3 1/2
A6	88.9	R 3	3 1/2
	88.9	R 3	3 1/2
	100		
	101.6	R 3 1/2	4 1/4
	108		5
	114.3	R 4	5 1/4
A7	127		5 1/4
	133		5 1/4
	133		
	139.7	R 5	
	152.4		6
	159		6 1/4
A8	165		6 1/2
	168.3	R 6	
	168.3	R 6	
	177.8		7
	193.7		7 5/8
	216		8 1/2
A9	219.1	R 8	
	219.1	R 8	
	244.5		
	273	R 10	
A10	323.9	R 12	
	355.6	R 14	
	406.4	R 16	

Ölçü Tablosu Dimension Table						Sipariş Kodu Order Code
L1	L2	H1	H2	S min.	Genişlik Width	
238	122	70	150	2	120	CM61M11P1YA5065.0 CM61M11P1YA5070.0 CM61M11P1YA5073.0 CM61M11P1YA5076.1 CM61M11P1YA5080.0 CM61M11P1YA5082.5 CM61M11P1YA5088.9
309	168	99	211	2	160	CM61M11P1YA6088.9 CM61M11P1YA6100.0 CM61M11P1YA6101.6 CM61M11P1YA6108.0 CM61M11P1YA6114.3 CM61M11P1YA6127.0 CM61M11P1YA6133.0
370	205	115	245	3	182	CM61M11P1YA7133.0 CM61M11P1YA7139.7 CM61M11P1YA7152.4 CM61M11P1YA7159.0 CM61M11P1YA7165.0 CM61M11P1YA7168.3
440	265	160	339	3	240	CM61M11P1YA8168.3 CM61M11P1YA8177.8 CM61M11P1YA8193.7 CM61M11P1YA8216.0 CM61M11P1YA8219.1
590	395	235	489	8	354	CM61M11P1YA9219.1 CM61M11P1YA9244.5 CM61M11P1YA9273.0 CM61M11P1YA9323.9
750	534	295	609	18	364	CM61M11P1YA0355.6 CM61M11P1YA0406.4



Metal + Kaplama Tipi Metal + Surface Finishing		Gövde Malzemesi Clamp Body Material	
0	Kaplamasız / Uncoated	A	Alüminyum / Aluminum
1	Fosfat / Phosphated / Fe/Znph	N	Polyamid / Polyamide
3	Galvaniz / Galvanized / Fe/Zn 8C Cr3-B	T	TPE
4	CrNi 304 AISI 304	P	Polipropilen / Polypropylene
6	CrNi 316 AISI 316		
9	Çinko Nikel / Zinc Nickel Fe/ZnNi		

Farklı malzeme talepleriniz için lütfen LMC Makina'ya danışınız.

For different material request please consult LMC Makina.

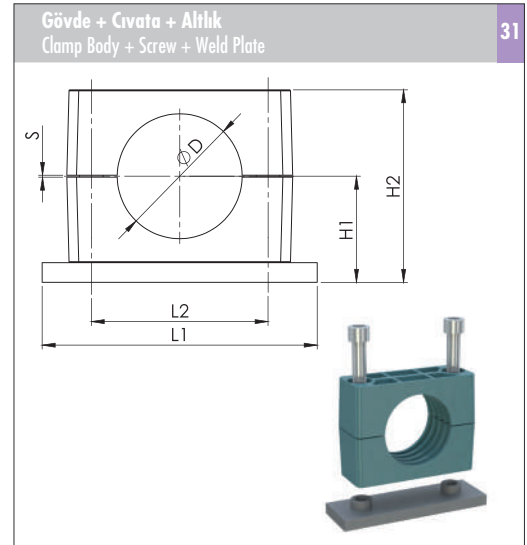
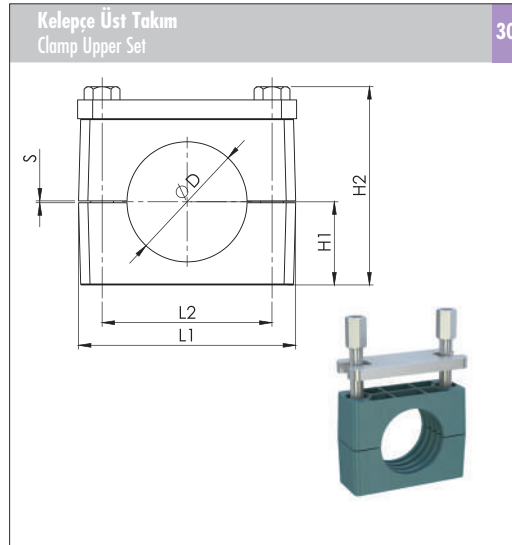

CDaaM63PIYA1XX.X

Metal + Kaplama Tipi  
Metal + Surface Finishing  
 Gövde Malzemesi  
Clamp Body Material  
 Gövde Renk  
Clamp Body Colour  
 Grup  
Group  
 Ölçü Site  
Size

CM00M01PIYA1XX.X

Metal + Kaplama Tipi  
Metal + Surface Finishing  
 Gövde Malzemesi  
Clamp Body Material  
 Gövde Renk  
Clamp Body Colour  
 Grup  
Group  
 Ölçü Site  
Size

Grup	Dış Çap (ØD)	Anma Çapı (R) Boru Dış	Dış Çap (ØD)
Group	O.D. of Pipe / Tube / Hose mm	Nominal Bore Pipe inch	O.D. of Pipe / Tube / Hose inch
A1	6		
	6.4		1/4
	8		5/16
	9.5		3/8
	10	R 1/8	
	12		
	12.7		1/2
	13.5	R 1/4	
	14		
	15		
16		5/8	
17.2	R 3/8		
18			
A2	19		3/4
	20		
	21.3	R 1/2	
	22		7/8
	25		
	25.4		1
	26.9	R 3/4	
	28		
	30		
	A3	30	
32			1 1/4
33.7		R 1	
35			
38			1 1/2
40			
42		R 1 1/4	
A4	38		1 1/2
	42		
	44.5		1 3/4
	48.3	R 1 1/2	
	50.8		2
	55		
	57		2 1/4
	60.3	R 2	
	63.5		2 1/2
	65		
70		2 3/4	

**Ölçü Tablosu**  
Dimension Table

L1	L2	H1	H2	S min.	Genişlik Width
55	33	16	47	0.6	30
70	45	24	63	0.6	30
85	60	30	75	0.6	30
115	90	44.5	107	2	45

**Sipariş Kodu**  
Order Code

CDaaM63PIYA1006.0
CDaaM63PIYA1006.4
CDaaM63PIYA1008.0
CDaaM63PIYA1009.5
CDaaM63PIYA1010.0
CDaaM63PIYA1012.0
CDaaM63PIYA1012.7
CDaaM63PIYA1013.5
CDaaM63PIYA1014.0
CDaaM63PIYA1015.0
CDaaM63PIYA1016.0
CDaaM63PIYA1017.2
CDaaM63PIYA1018.0
CDaaM63PIYA2019.0
CDaaM63PIYA2020.0
CDaaM63PIYA2021.3
CDaaM63PIYA2022.0
CDaaM63PIYA2025.0
CDaaM63PIYA2025.4
CDaaM63PIYA2026.9
CDaaM63PIYA2028.0
CDaaM63PIYA2030.0
CDaaM63PIYA3030.0
CDaaM63PIYA3032.0
CDaaM63PIYA3033.7
CDaaM63PIYA3035.0
CDaaM63PIYA3038.0
CDaaM63PIYA3040.0
CDaaM63PIYA3042.0
CDaaM63PIYA4038.0
CDaaM63PIYA4042.0
CDaaM63PIYA4044.5
CDaaM63PIYA4048.3
CDaaM63PIYA4050.8
CDaaM63PIYA4055.0
CDaaM63PIYA4057.0
CDaaM63PIYA4060.3
CDaaM63PIYA4063.5
CDaaM63PIYA4065.0
CDaaM63PIYA4070.0

**Ölçü Tablosu**  
Dimension Table

L1	L2	H1	H2	S min.	Genişlik Width
74	33	24	40	0.6	30
86	45	32	56	0.6	30
100	60	38	68	0.6	30
140	90	54.5	99	2	45

**Sipariş Kodu**  
Order Code

CM00M01PIYA1006.0
CM00M01PIYA1006.4
CM00M01PIYA1008.0
CM00M01PIYA1009.5
CM00M01PIYA1010.0
CM00M01PIYA1012.0
CM00M01PIYA1012.7
CM00M01PIYA1013.5
CM00M01PIYA1014.0
CM00M01PIYA1015.0
CM00M01PIYA1016.0
CM00M01PIYA1017.2
CM00M01PIYA1018.0
CM00M01PIYA2019.0
CM00M01PIYA2020.0
CM00M01PIYA2021.3
CM00M01PIYA2022.0
CM00M01PIYA2025.0
CM00M01PIYA2025.4
CM00M01PIYA2026.9
CM00M01PIYA2028.0
CM00M01PIYA2030.0
CM00M01PIYA3030.0
CM00M01PIYA3032.0
CM00M01PIYA3033.7
CM00M01PIYA3035.0
CM00M01PIYA3038.0
CM00M01PIYA3040.0
CM00M01PIYA3042.0
CM00M01PIYA4038.0
CM00M01PIYA4042.0
CM00M01PIYA4044.5
CM00M01PIYA4048.3
CM00M01PIYA4050.8
CM00M01PIYA4055.0
CM00M01PIYA4057.0
CM00M01PIYA4060.3
CM00M01PIYA4063.5
CM00M01PIYA4065.0
CM00M01PIYA4070.0



Metal + Kaplama Tipi Metal + Surface Finishing		Gövde Malzemesi Clamp Body Material	
0	Kaplamasız / Uncoated	A	Alüminyum / Aluminum
1	Fosfat / Phosphated / Fe/Znph	N	Polyamid / Polyamide
3	Galvaniz / Galvanized / Fe/Zn 8C Cr3-B	T	TPE
4	CrNi 304 AISI 304	P	Polipropilene / Polypropylene
6	CrNi 316 AISI 316		
9	Çinko Nikel / Zinc Nickel / Fe/ZnNi		

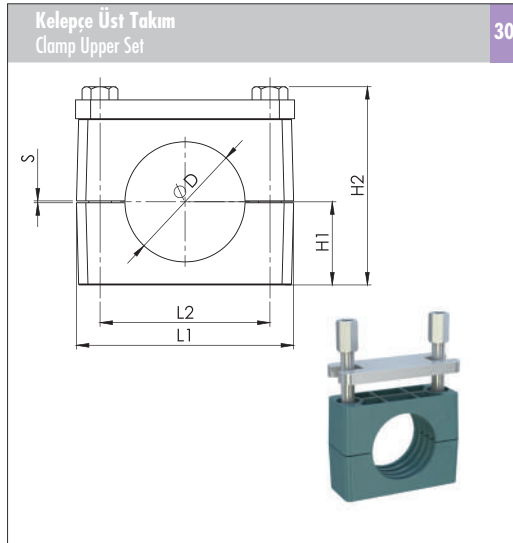

Farklı malzeme talepleriniz için lütfen LMC Makina'ya danışınız.

For different material request please consult LMC Makina.

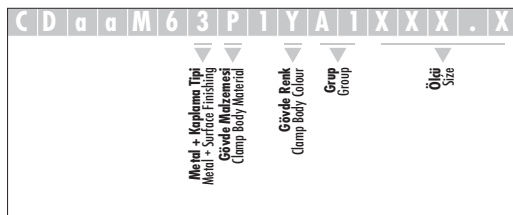

Grup Group	Dış Çap (ØD) O.D. of Pipe / Tube / Hose mm	Anma Çapı (R) Boru Dış Nominal Bore Pipe inch	Dış Çap (ØD) O.D. of Pipe / Tube / Hose inch
A5	65		
	70		
	73	R 2 1/2	2 7/8
	76.1	R 2 1/2	3
	80		
A6	82.5		3 1/4
	88.9	R 3	3 1/2
	88.9	R 3	3 1/2
	100		
	101.6	R 3 1/2	
	108		4 1/4
A7	114.3	R 4	
	127		5
	133		5 1/4
	133		
	139.7	R 5	
A8	152.4		6
	159		6 1/4
	165		6 1/2
	168.3	R 6	
	168.3	R 6	
A9	177.8		7
	193.7		7 5/8
	216		8 1/2
	219.1	R 8	
A10	219.1	R 8	
	244.5		
	273	R 10	
	323.9	R 12	
	355.6	R 14	
	406.4	R 16	

Ölçü Tablosu Dimension Table						Sipariş Kodu Order Code
L1	L2	H1	H2	S min.	Genişlik Width	
154	122	60	140	2	60	CDaaM63P1YA5065.0 CDaaM63P1YA5070.0 CDaaM63P1YA5073.0 CDaaM63P1YA5076.1 CDaaM63P1YA5080.0 CDaaM63P1YA5082.5 CDaaM63P1YA5088.9
						CDaaM63P1YA6088.9 CDaaM63P1YA6100.0 CDaaM63P1YA6101.6 CDaaM63P1YA6108.0 CDaaM63P1YA6114.3 CDaaM63P1YA6127.0 CDaaM63P1YA6133.0
						CDaaM63P1YA7133.0 CDaaM63P1YA7139.7 CDaaM63P1YA7152.4 CDaaM63P1YA7159.0 CDaaM63P1YA7165.0 CDaaM63P1YA7168.3
						CDaaM63P1YA8168.3 CDaaM63P1YA8177.8 CDaaM63P1YA8193.7 CDaaM63P1YA8216.0 CDaaM63P1YA8219.1
						CDaaM63P1YA9219.1 CDaaM63P1YA9244.5 CDaaM63P1YA9273.0 CDaaM63P1YA9323.9
630	534	265	579	18	180	CDaaM63P1YA0355.6 CDaaM63P1YA0406.4



Gövde Malzemesi Clamp Body Material	Metal + Kaplama Tipi Metal + Surface Finishing	Vida Tipi Thread Type
A Alüminyum / Aluminum	0 Kaplamasız / Uncoated	C UNC
N Polyamid / Polyamide	1 Fosfat / Phosphated / Fe/Znph	F UNF
T TPE	3 Galvaniz / Galvanized / Fe/Zn 8C Cr3-B	M Metrik / Metric
P Polipropilen / Polypropylene	4 CrNi 304 AISI 304	W Whitworth
	6 CrNi 316 AISI 316	
	9 Çinko Nikel / Zinc Nickel Fe/ZnNi	

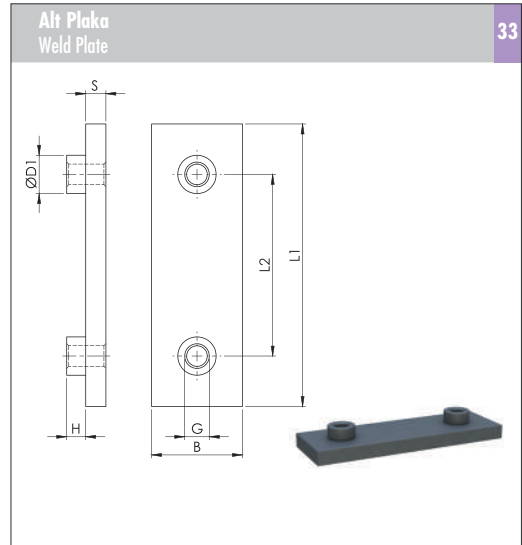
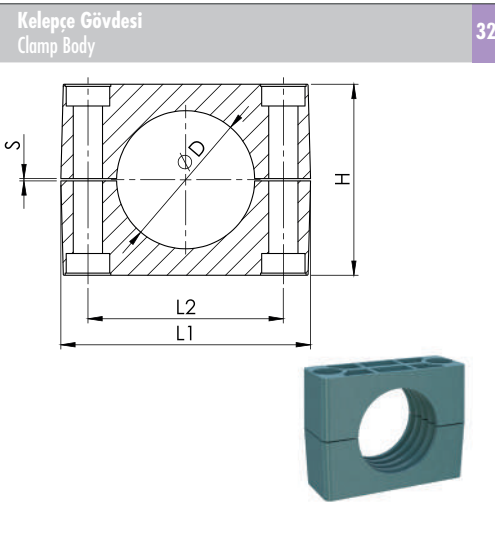

Farklı malzeme talepleriniz için lütfen LMC Makina'ya danışınız.

For different material request please consult LMC Makina.

C 2 P 1 Y A 1 X X X . X

Gövde Malzemesi / Clamp Body Material  
 Kelepçe Tipi / Clamp Body Design  
 Kelepçe Renk / Clamp Body Colour  
 Grup / Group  
 Ölçü / Size

C A 0 0 M 1 A 1

Vida Tipi / Thread Type  
 Metal + Kaplama Tipi / Metal + Surface Finishing  
 Grup / Group

Grup	Dış Çap (ØD)	Anma Çapı (R) Boru Dış	Dış Çap (ØD)
Group	O.D. of Pipe / Tube / Hose mm	Nominal Bore Pipe inch	O.D. of Pipe / Tube / Hose inch
A1	6		
	6.4		1/4
	8		5/16
	9.5		3/8
	10	R 1/8	
	12		
	12.7		1/2
	13.5	R 1/4	
	14		
	15		
16		5/8	
17.2	R 3/8		
18			
A2	19		3/4
	20		
	21.3	R 1/2	
	22		7/8
	25		
	25.4		1
	26.9	R 3/4	
	28		
	30		
	A3	30	
32			1 1/4
33.7		R 1	
35			
38			1 1/2
40			
42		R 1 1/4	
A4	38		1 1/2
	42		
	44.5		1 3/4
	48.3	R 1 1/2	
	50.8		2
	55		
	57		2 1/4
	60.3	R 2	
	63.5		2 1/2
	65		
70		2 3/4	

**Ölçü Tablosu**  
Dimension Table

L1	L2	H	S min.	Genişlik Width	Sipariş Kodu Order Code
					C2P1YA1006.0
					C2P1YA1006.4
					C2P1YA1008.0
					C2P1YA1009.5
					C2P1YA1010.0
					C2P1YA1012.0
55	33	32	0.6	30	C2P1YA1012.7
					C2P1YA1013.5
					C2P1YA1014.0
					C2P1YA1015.0
					C2P1YA1016.0
					C2P1YA1017.2
					C2P1YA1018.0
					C2P1YA2019.0
					C2P1YA2020.0
					C2P1YA2021.3
					C2P1YA2022.0
70	45	48	0.6	30	C2P1YA2025.0
					C2P1YA2025.4
					C2P1YA2026.9
					C2P1YA2028.0
					C2P1YA2030.0
					C2P1YA3030.0
					C2P1YA3032.0
					C2P1YA3033.7
85	60	50	0.6	30	C2P1YA3035.0
					C2P1YA3038.0
					C2P1YA3040.0
					C2P1YA3042.0
					C2P1YA4038.0
					C2P1YA4042.0
					C2P1YA4044.5
					C2P1YA4048.3
					C2P1YA4050.8
115	90	89	2	45	C2P1YA4055.0
					C2P1YA4057.0
					C2P1YA4060.3
					C2P1YA4063.5
					C2P1YA4065.0
					C2P1YA4070.0

**Ölçü Tablosu**  
Dimension Table

L1	L2	H	S	G	B	ØD1	Sipariş Kodu Order Code
74	33	8	8	M10 3/8-16 UNC	30	18	CA00M1A1
86	45	8	8	M10 3/8-16 UNC	30	18	CA00M1A2
100	60	8	8	M10 3/8-16 UNC	30	18	CA00M1A3
140	90	8	10	M12 7/16-14 UNC	45	20	CA00M1A4

Gövde Malzemesi Clamp Body Material	Metal + Kaplama Tipi Metal + Surface Finishing	Vida Tipi Thread Type
A Alüminyum / Aluminum	0 Kaplamsız / Uncoated	C UNC
N Polyamid / Polyamide	1 Fosfat / Phosphated / Fe/Znph	F UNF
T TPE	3 Galvaniz / Galvanized / Fe/Zn 8C Cr3-B	M Metrik / Metric
P Polipropilen / Polypropylene	4 CrNi 304 AISI 304	W Whitworth
	6 CrNi 316 AISI 316	
	9 Çinko Nikel / Zinc Nickel Fe/ZnNi	

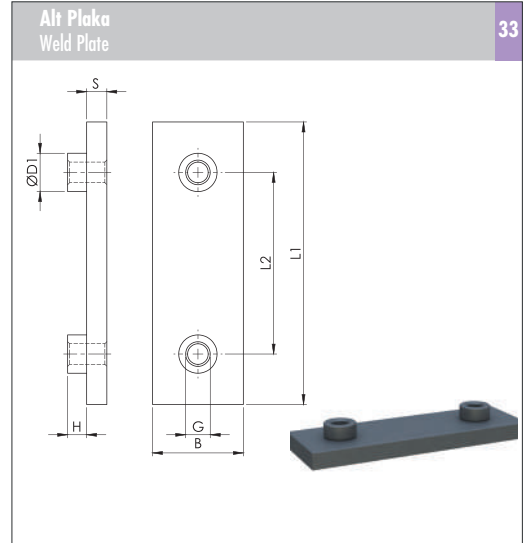
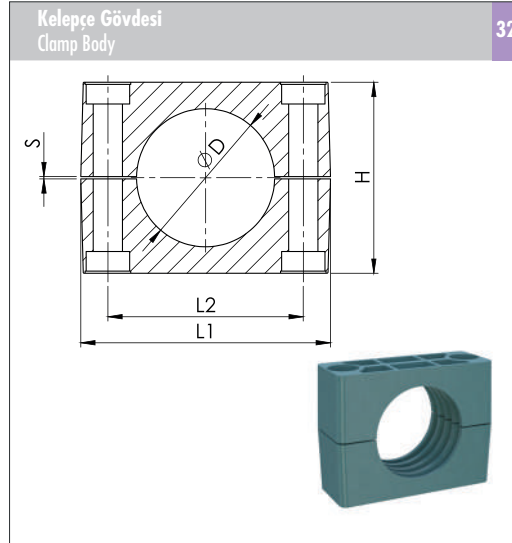

Farklı malzeme talepleriniz için lütfen LMC Makina'ya danışınız.

For different material request please consult LMC Makina.

C 2 P 1 Y A 1 X X X . X

Gövde Malzemesi  
Clamp Body Material  
 Gövde Tipi  
Clamp Body Design  
 Gövde Renk  
Clamp Body Colour  
 Grup  
Group  
 Ölçü  
Size

C A 0 0 M 1 A 1

Vida Tipi  
Thread Type  
 Metal + Kaplama Tipi  
Metal + Surface Finishing  
 Grup  
Group

Grup Group	Dış Çap (ØD) O.D. of Pipe / Tube/Hose mm	Anma Çapı (R) Boru Dış Nominal Bore Pipe inch	Dış Çap (ØD) O.D. of Pipe / Tube/Hose inch
A5	65		
	70		
	73	R 2 1/2 <small>except DIN EN 10220</small>	2 7/8
	76.1	R 2 1/2 <small>only DIN EN 10220</small>	3
	80		3 1/4
	82.5		3 1/2
A6	88.9	R 3	3 1/2
	88.9	R 3	3 1/2
	100		
	101.6	R 3 1/2	4 1/4
	108		
	114.3	R 4	5
A7	127		5 1/4
	133		
	139.7	R 5	6
	152.4		6 1/4
	159		6 1/2
	165		
A8	168.3	R 6	7
	168.3	R 6	7 5/8
	177.8		8 1/2
	193.7		
	216		
	219.1	R 8	
A9	219.1	R 8	
	244.5		
	273	R 10	
A10	323.9	R 12	
	355.6	R 14	
	406.4	R 16	

**Ölçü Tablosu**  
Dimension Table

L1	L2	H	S min.	Genişlik Width
154	122	120	2	60
206	168	168	2	80
251	205	200	3	91
335	265	270	3	120
470	395	410	8	162
630	534	530	18	182

**Sipariş Kodu**  
Order Code

C2P1YA5065.0  
C2P1YA5070.0  
C2P1YA5073.0  
C2P1YA5076.1  
C2P1YA5080.0  
C2P1YA5082.5  
C2P1YA5088.9  
C2P1YA6088.9  
C2P1YA6100.0  
C2P1YA6101.6  
C2P1YA6108.0  
C2P1YA6114.3  
C2P1YA6127.0  
C2P1YA6133.0  
C2P1YA7133.0  
C2P1YA7139.7  
C2P1YA7152.4  
C2P1YA7159.0  
C2P1YA7165.0  
C2P1YA7168.3  
C2P1YA8168.3  
C2P1YA8177.8  
C2P1YA8193.7  
C2P1YA8216.0  
C2P1YA8219.1  
C2P1YA9219.1  
C2P1YA9244.5  
C2P1YA9273.0  
C2P1YA9323.9  
C2P1YA0355.6  
C2P1YA0406.4

**Ölçü Tablosu**  
Dimension Table

L1	L2	H	S	G	B	ØD1
180	122	12	10	M16 5/8-11 UNC	60	24
226	168	18	15	M20 3/4-10 UNC	80	30
270	205	21	15	M24 7/8-9 UNC	90	35
340	265	21	25	M30 1-1/8-7 UNC	120	45
520	395	38	30	M30 1-1/8-7 UNC	160	50
680	534	38	30	M30 1-1/8-7 UNC	180	50

**Sipariş Kodu**  
Order Code

CA00M1A5  
CA00M1A6  
CA00M1A7  
CA00M1A8  
CA00M1A9  
CA00M1A0

Metal + Kaplama Tipi Metal + Surface Finishing		Vida Tipi Thread Type	
0	Kaplamasız / Uncoated	C	UNC
1	Fosfat / Phosphated / Fe/Znph	F	UNF
3	Galvaniz / Galvanized / Fe/Zn 8C Cr3-B	M	Metrik / Metric
4	CrNi 304 AISI 304	W	Whitworth
6	CrNi 316 AISI 316		
9	Çinko Nikel / Zinc Nickel Fe/ZnNi		

Farklı malzeme talepleriniz için lütfen LMC Makina'ya danışınız.

For different material request please consult LMC Makina.

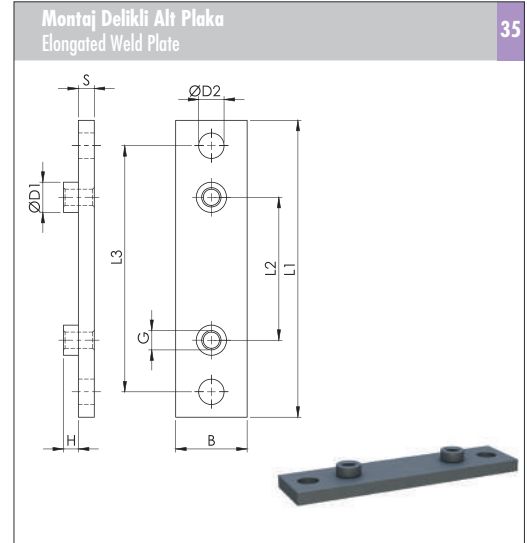
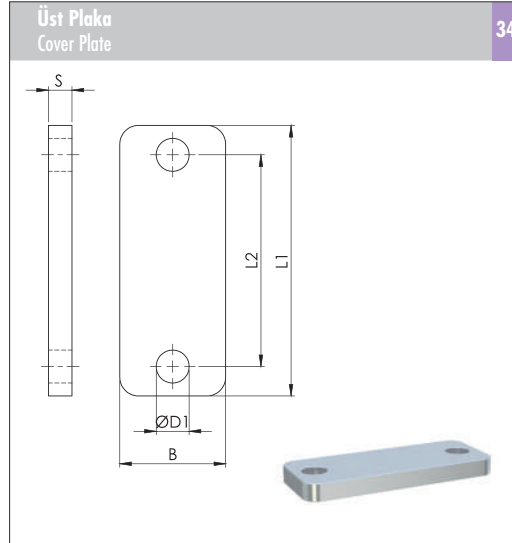

C	U	O	O	T	3	A	1
					↓ Metal + Kaplama Tipi Metal + Surface Finishing		↓ Grup Group

C	A	O	I	M	1	A	1
				↓ Vida Tipi Thread type		↓ Metal + Kaplama Tipi Metal + Surface Finishing	↓ Grup Group

Grup	Dış Çap (ØD)	Anma Çapı (R) Boru Dış	Dış Çap (ØD)
Group	O.D. of Pipe / Tube / Hose mm	Nominal Bore Pipe inch	O.D. of Pipe / Tube / Hose inch
A1	6		
	6.4		1/4
	8		5/16
	9.5		3/8
	10	R 1/8	
	12		
	12.7		1/2
	13.5	R 1/4	
	14		
	15		
16		5/8	
17.2	R 3/8		
18			
A2	19		3/4
	20		
	21.3	R 1/2	
	22		7/8
	25		
	25.4		1
	26.9	R 3/4	
	28		
	30		
	A3	30	
32			1 1/4
33.7		R 1	
35			
38			1 1/2
40			
42	R 1 1/4		
A4	38		1 1/2
	42		
	44.5		1 3/4
	48.3	R 1 1/2	
	50.8		2
	55		
	57		2 1/4
	60.3	R 2	
	63.5		2 1/2
	65		
70		2 3/4	

Ölçü Tablosu					Sipariş Kodu
Dimension Table					Order Code
L1	L2	B	S	ØD1	
55	33	30	8	11	CU00T3A1
70	45	30	8	11	CU00T3A2
85	60	30	8	11	CU00T3A3
115	90	45	10	14	CU00T3A4

Ölçü Tablosu										Sipariş Kodu
Dimension Table										Order Code
L1	L2	L3	H	S	G	B	ØD1	ØD2		
113	33	85	8	8	M10 3/8-16 UNC	30	18	13		CA01M1A1
125	45	97	8	8	M10 3/8-16 UNC	30	18	13		CA01M1A2
140	60	112	8	8	M10 3/8-16 UNC	30	18	13		CA01M1A3
187	90	155	8	10	M12 7/16-14 UNC	45	20	16		CA01M1A4

Metal + Kaplama Tipi Metal + Surface Finishing		Vida Tipi Thread Type	
0	Kaplamasız / Uncoated	C	UNC
1	Fosfat / Phosphated / Fe/Znph	F	UNF
3	Galvaniz / Galvanized / Fe/Zn 8C Cr3-B	M	Metrik / Metric
4	CrNi 304 AISI 304	W	Whitworth
6	CrNi 316 AISI 316		
9	Çinko Nikel / Zinc Nickel Fe/ZnNi		

Farklı malzeme talepleriniz için lütfen LMC Makina'ya danışınız.

For different material request please consult LMC Makina.

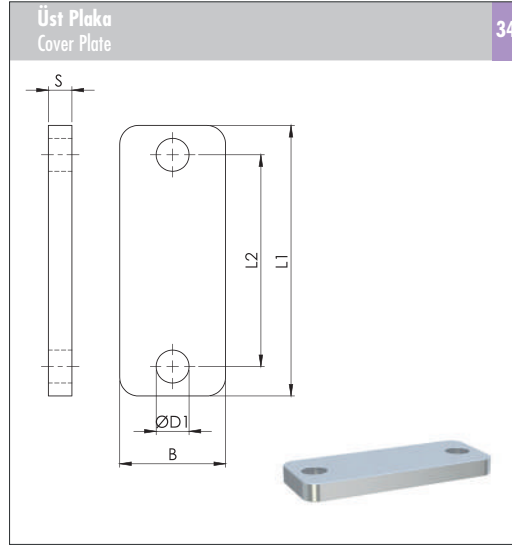

C	U	O	O	T	3	A	1
					▼ Metal + Kaplama Tipi Metal + Surface Finishing		▼ Grup Group

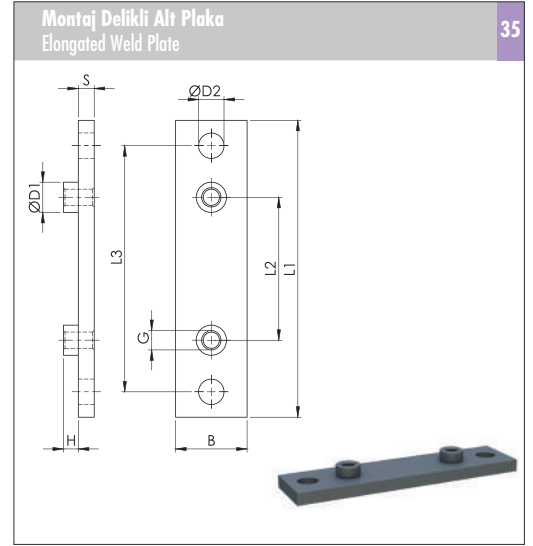

C	A	O	I	M	1	A	1
				▼ Vida Tipi Thread Type	▼ Metal + Kaplama Tipi Metal + Surface Finishing		▼ Grup Group

Grup Group	Dış Çap (ØD) O.D. of Pipe / Tube/Hose mm	Anma Çapı (R) Boru Dış Nominal Bore Pipe inch	Dış Çap (ØD) O.D. of Pipe / Tube/Hose inch
A5	65		
	70		
	73	R 2 1/2	2 7/8
	76.1	R 2 1/2	3
	80		
A6	82.5		3 1/4
	88.9	R 3	3 1/2
	88.9	R 3	3 1/2
	100		
	101.6	R 3 1/2	
A7	108	R 4	4 1/4
	114.3		
	127		5
	133		5 1/4
	133		
A8	139.7	R 5	
	152.4		6
	159		6 1/4
	165		6 1/2
	168.3	R 6	
A9	168.3	R 6	
	177.8		7
	193.7		7 5/8
	216		8 1/2
	219.1	R 8	
A10	219.1	R 8	
	244.5		
	273	R 10	
A10	323.9	R 12	
	355.6	R 14	
	406.4	R 16	

Ölçü Tablosu Dimension Table					Sipariş Kodu Order Code
L1	L2	B	S	ØD1	
152	122	60	10	19	CU00T3A5
206	168	80	15	22	CU00T3A6
251	205	90	15	26	CU00T3A7
340	265	120	25	35	CU00T3A8
470	395	160	30	35	CU00T3A9
630	534	180	30	35	CU00T3A0

Ölçü Tablosu Dimension Table								Sipariş Kodu Order Code	
L1	L2	L3	H	S	G	B	ØD1	ØD2	
238	122	198	12	10	M16 5/8-11 UNC	60	24	21	CA01M1A5
309	168	259	18	15	M20 3/4-10 UNC	80	30	26	CA01M1A6
370	205	310	21	15	M24 7/8-9 UNC	90	35	31	CA01M1A7
440	265	380	21	25	M30 1-1/8-7 UNC	120	45	31	CA01M1A8
590	395	530	38	30	M30 1-1/8-7 UNC	160	50	31	CA01M1A9
750	534	690	38	30	M30 1-1/8-7 UNC	180	50	31	CA01M1A0

Metal + Kaplama Tipi Metal + Surface Finishing		Vida Tipi Thread Type	
0	Kaplamasız / Uncoated	C	UNC
1	Fosfat / Phosphated / Fe/Znph	F	UNF
3	Galvaniz / Galvanized / Fe/Zn 8C Cr3-B	M	Metrik / Metric
4	CrNi 304 AISI 304	W	Whitworth
6	CrNi 316 AISI 316		
9	Çinko Nikel / Zinc Nickel Fe/ZnNi		

Farklı malzeme talepleriniz için lütfen LMC Makina'ya danışınız.

For different material request please consult LMC Makina.

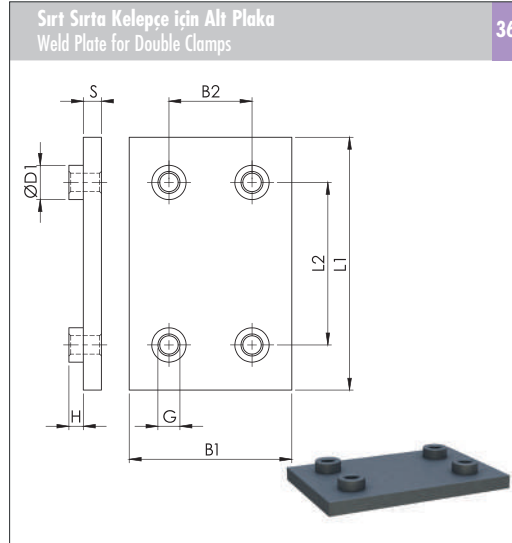

C	A	2	0	M	1	A	1
				Vida Tipi Thread Type		Metal + Kaplama Tipi Metal + Surface Finishing	Grup Group

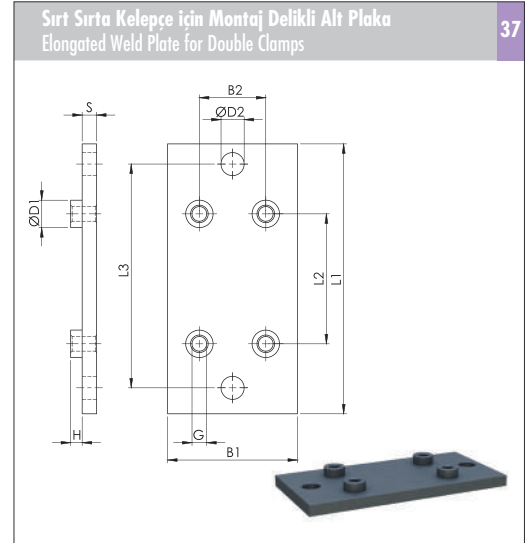

C	A	2	1	M	1	A	1
				Vida Tipi Thread Type		Metal + Kaplama Tipi Metal + Surface Finishing	Grup Group

Grup Group	Dış Çap (ØD) O.D. of Pipe / Tube/Hose mm	Anma Çapı (R) Boru Dış Nominal Bore Pipe inch	Dış Çap (ØD) O.D. of Pipe / Tube/Hose inch
A1	6		
	6.4		1/4
	8		5/16
	9.5		3/8
	10	R 1/8	
	12		
	12.7		1/2
	13.5	R 1/4	
	14		
	15		
16		5/8	
17.2	R 3/8		
18			
A2	19		3/4
	20		
	21.3	R 1/2	
	22		7/8
	25		
	25.4		1
	26.9	R 3/4	
	28		
	30		
	A3	30	
32			1 1/4
33.7		R 1	
35			
38			1 1/2
40			
42		R 1 1/4	
A4	38		1 1/2
	42		
	44.5		1 3/4
	48.3	R 1 1/2	
	50.8		2
	55		
	57		2 1/4
	60.3	R 2	
	63.5		2 1/2
	65		
70		2 3/4	

Ölçü Tablosu Dimension Table								Sipariş Kodu Order Code
L1	L2	B1	B2	H	S	G	ØD1	
74	33	60	31	8	8	M10 3/8-16 UNC	18	CA20M1A1
86	45	60	31	8	8	M10 3/8-16 UNC	18	CA20M1A2
100	60	60	31	8	8	M10 3/8-16 UNC	18	CA20M1A3
140	90	90	46	8	10	M12 7/16-14 UNC	20	CA20M1A4

Ölçü Tablosu Dimension Table										Sipariş Kodu Order Code
L1	L2	L3	B1	B2	H	S	G	ØD1	ØD2	
113	33	85	60	31	8	8	M10 3/8-16 UNC	18	13	CA21M1A1
125	45	97	60	31	8	8	M10 3/8-16 UNC	18	13	CA21M1A2
140	60	112	60	31	8	8	M10 3/8-16 UNC	18	13	CA21M1A3
187	90	155	90	46	8	10	M12 7/16-14 UNC	20	16	CA21M1A4

Metal + Kaplama Tipi Metal + Surface Finishing		Vida Tipi Thread Type	
0	Kaplamasız / Uncoated	C	UNC
1	Fosfat / Phosphated / Fe/Znph	F	UNF
3	Galvaniz / Galvanized / Fe/Zn 8C Cr3-B	M	Metrik / Metric
4	CrNi 304 AISI 304	W	Whitworth
6	CrNi 316 AISI 316		
9	Çinko Nikel / Zinc Nickel Fe/ZnNi		

Farklı malzeme talepleriniz için lütfen LMC Makina'ya danışınız.

For different material request please consult LMC Makina.

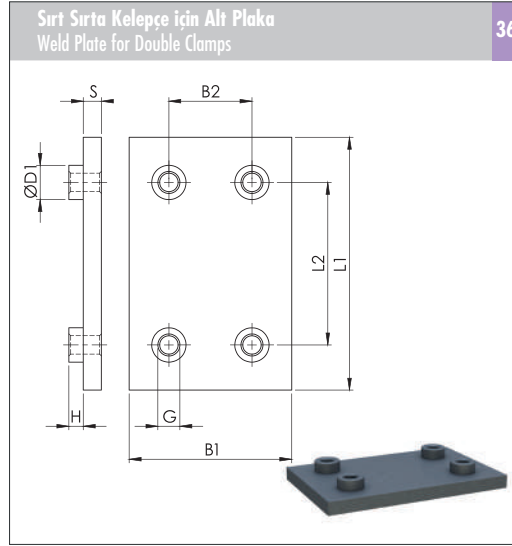

C	A	2	0	M	1	A	1
				Vida Tipi Thread Type		Metal + Kaplama Tipi Metal + Surface Finishing	Grup Group

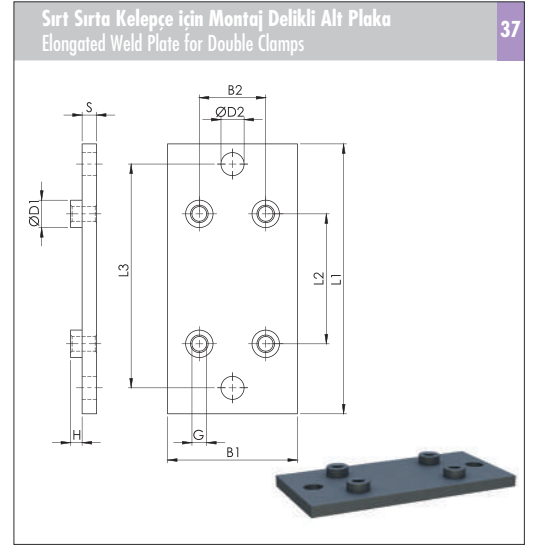

C	A	2	1	M	1	A	1
				Vida Tipi Thread Type		Metal + Kaplama Tipi Metal + Surface Finishing	Grup Group

Grup Group	Dış Çap (ØD) O.D. of Pipe / Tube / Hose mm	Anma Çapı (R) Boru Dış Nominal Bore Pipe inch	Dış Çap (ØD) O.D. of Pipe / Tube / Hose inch
A5	65		
	70		
	73	R 2 1/2 <small>except DIN EN 10220</small>	2 7/8
	76.1	R 2 1/2 <small>only DIN EN 10220</small>	3
	80		
A6	82.5		3 1/4
	88.9	R 3	3 1/2
	88.9	R 3	3 1/2
	100		
	101.6	R 3 1/2	4 1/4
A7	108	R 4	5
	114.3		5 1/4
	127		5 1/4
	133		5 1/4
	139.7	R 5	6
A8	152.4		6 1/4
	159		6 1/2
	165		
	168.3	R 6	7
	168.3	R 6	7 5/8
A9	177.8		8 1/2
	193.7		
	216	R 8	
A10	219.1	R 8	
	244.5		
	273	R 10	
	323.9	R 12	
	355.6	R 14	
	406.4	R 16	

Ölçü Tablosu Dimension Table								Sipariş Kodu Order Code
L1	L2	B1	B2	H	S	G	ØD1	
180	122	120	61	12	10	M16 5/8-11 UNC	24	CA20M1A5
226	168	160	81	18	15	M20 3/4-10 UNC	30	CA20M1A6
270	205	182	93	21	15	M24 7/8-9 UNC	35	CA20M1A7
340	265	240	122	21	25	M30 1-1/8-7 UNC	45	CA20M1A8
520	395	324	166	38	30	M30 1-1/8-7 UNC	50	CA20M1A9
680	534	364	186	38	30	M30 1-1/8-7 UNC	50	CA20M1A0

Ölçü Tablosu Dimension Table										Sipariş Kodu Order Code
L1	L2	L3	B1	B2	H	S	G	ØD1	ØD2	
238	122	198	120	61	12	10	M16 5/8-11 UNC	24	21	CA21M1A5
309	168	259	160	81	18	15	M20 3/4-10 UNC	30	26	CA21M1A6
370	205	310	182	93	21	15	M24 7/8-9 UNC	35	31	CA21M1A7
440	265	380	240	124	21	25	M30 1-1/8-7 UNC	45	31	CA21M1A8
590	395	530	326	166	38	30	M30 1-1/8-7 UNC	50	31	CA21M1A9
750	534	690	364	186	38	30	M30 1-1/8-7 UNC	50	31	CA21M1A0

Metal + Kaplama Tipi Metal + Surface Finishing		Vida Tipi Thread Type	
0	Kaplanmaz / Uncoated	C	UNC
1	Fosfat / Phosphated / Fe/Znph	F	UNF
3	Galvaniz / Galvanized / Fe/Zn 8C Cr3-B	M	Metrik / Metric
4	CrNi 304 AISI 304	W	Whitworth
6	CrNi 316 AISI 316		
9	Çinko Nikel / Zinc Nickel Fe/ZnNi		

Farklı malzeme talepleriniz için lütfen LMC Makina'ya danışınız.

For different material request please consult LMC Makina.

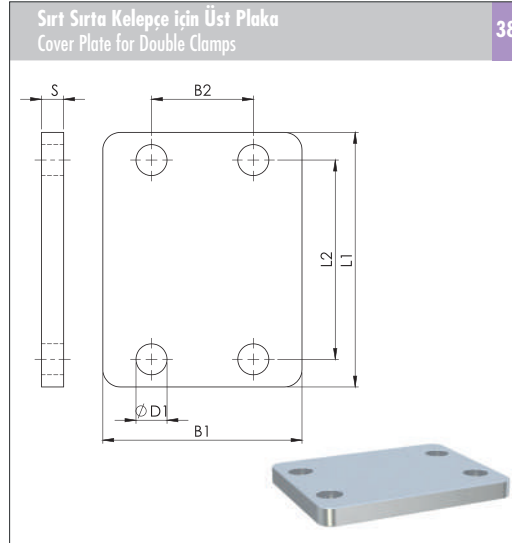

C	U	2	0	T	3	A	1
					↓ Metal + Kaplama Tipi Metal + Surface Finishing		
						↓ Grup Group	

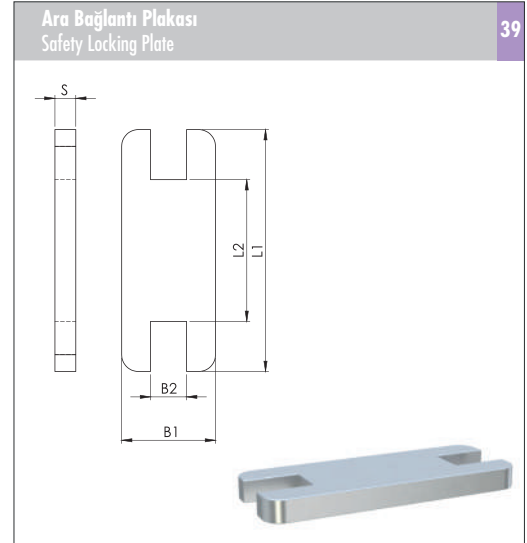

C	H	0	0	T	3	A	1
					↓ Metal + Kaplama Tipi Metal + Surface Finishing		
						↓ Grup Group	

Grup Group	Dış Çap (ØD) O.D. of Pipe / Tube/Hose mm	Anma Çapı (R) Boru Dış Nominal Bore Pipe inch	Dış Çap (ØD) O.D. of Pipe / Tube/Hose inch
A1	6		
	6.4		1/4
	8		5/16
	9.5		3/8
	10	R 1/8	
	12		
	12.7		1/2
	13.5	R 1/4	
	14		
	15		
16		5/8	
17.2	R 3/8		
18			
A2	19		3/4
	20		
	21.3	R 1/2	
	22		7/8
	25		
	25.4		1
	26.9	R 3/4	
	28		
	30		
	A3	30	
32			1 1/4
33.7		R 1	
35			
38			1 1/2
40			
42		R 1 1/4	
A4	38		1 1/2
	42		
	44.5		1 3/4
	48.3	R 1 1/2	
	50.8		2
	55		
	57		2 1/4
	60.3	R 2	
	63.5		2 1/2
	65		
70		2 3/4	

Ölçü Tablosu Dimension Table						Sipariş Kodu Order Code
L1	L2	B1	B2	S	ØD1	
55	33	60	31	8	11	CU20T3A1
70	45	60	31	8	11	CU20T3A2
85	60	60	31	8	11	CU20T3A3
115	90	90	46	10	14	CU20T3A4

Ölçü Tablosu Dimension Table					Sipariş Kodu Order Code
L1	L2	B1	B2	S	
56	13.5	30	15	8	CH00T3A1
70	25	30	15	8	CH00T3A2
85	40	30	15	8	CH00T3A3
116	68	45	17	10	CH00T3A4



Metal + Kaplama Tipi	
Metal + Surface Finishing	
0	Kaplamasız / Uncoated
1	Fosfat / Phosphated / Fe/Znph
3	Galvaniz / Galvanized / Fe/Zn 8C Cr3-B
4	CrNi 304 / AISI 304
6	CrNi 316 / AISI 316
9	Çinko Nikel / Zinc Nickel - Fe/ZnNi

Farklı malzeme talepleriniz için lütfen LMC Makina'ya danışınız.

For different material request please consult LMC Makina.

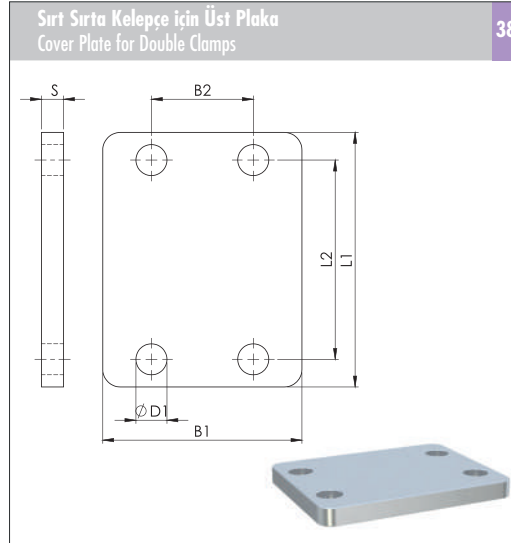

C	U	2	0	T	3	A	1
						Metal + Kaplama Tipi Metal + Surface Finishing	Grup Group

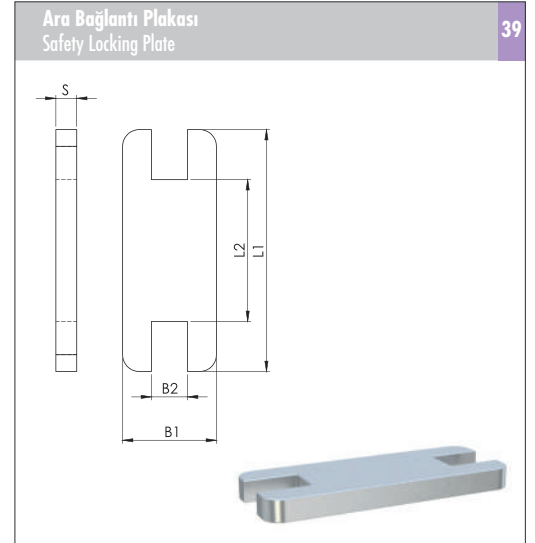

C	H	0	0	T	3	A	1
						Metal + Kaplama Tipi Metal + Surface Finishing	Grup Group

Grup	Dış Çap (ØD)	Anma Çapı (R) Boru Dış	Dış Çap (ØD)
Group	O. D. of Pipe / Tube / Hose mm	Nominal Bore Pipe inch	O. D. of Pipe / Tube / Hose inch
A5	65		
	70		
	73	R 2 1/2	2 7/8
	76.1	R 2 1/2	3
	80		
A6	82.5		3 1/4
	88.9	R 3	3 1/2
	88.9	R 3	3 1/2
	100		
	101.6	R 3 1/2	
A7	108		4 1/4
	114.3	R 4	
	127		5
	133		5 1/4
	133		
A8	139.7	R 5	
	152.4		6
	159		6 1/4
	165		6 1/2
	168.3	R 6	
A9	168.3	R 6	
	177.8		7
	193.7		7 5/8
	216		8 1/2
	219.1	R 8	
A10	219.1	R 8	
	244.5		
	273	R 10	
	323.9	R 12	
	355.6	R 14	
	406.4	R 16	

Ölçü Tablosu						Sipariş Kodu
Dimension Table						Order Code
L1	L2	B1	B2	S	ØD1	
152	122	120	61	10	19	CU20T3A5
206	168	160	81	15	22	CU20T3A6
251	205	182	93	15	26	CU20T3A7
320	265	240	122	25	35	CU20T3A8
470	395	324	166	30	35	CU20T3A9
630	534	364	186	30	35	CU20T3A0

Ölçü Tablosu					Sipariş Kodu
Dimension Table					Order Code
L1	L2	B1	B2	S	
153	97	60	21	10	CH00T3A5
206	130	80	27	15	CH00T3A6
251	166	90	30	15	CH00T3A7
325	205	120	49	25	CH00T3A8

Metal + Kaplama Tipi Metal + Surface Finishing		Vida Tipi Thread Type	
0	Kaplamasız / Uncoated	C	UNC
1	Fosfat / Phosphated / Fe/Znph	F	UNF
3	Galvaniz / Galvanized / Fe/Zn 8C Cr3-B	M	Metrik / Metric
4	CrNi 304 AISI 304	W	Whitworth
6	CrNi 316 AISI 316		
9	Çinko Nikel / Zinc Nickel Fe/ZnNi		

Farklı malzeme talepleriniz için lütfen LMC Makina'ya danışınız.

For different material request please consult LMC Makina.

**Altıköşe Başlı Cıvata**  
Hexagon Head Bolt

40

DIN 931 / 933 - ISO 4014

**Ara Bağlantı Cıvatası**  
Stacking Bolt

41

C C A M 3 0 1 0 0 4 5

Vida Tipi  
Thread Type

Metal + Kaplama Tipi  
Metal + Surface Finishing

Vida Ölçüsü  
Screw-Bolt Size

Cıvata Boyu  
Screw-Bolt Length

C C B M 3 0 1 0 0 2 4

Vida Tipi  
Thread Type

Metal + Kaplama Tipi  
Metal + Surface Finishing

Vida Ölçüsü  
Screw-Bolt Size

Cıvata Boyu  
Screw-Bolt Length

Grup	Dış Çap (ØD)	Anma Çapı (R) Boru Dışı	Dış Çap (ØD)
Group	O.D. of Pipe / Tube / Hose mm	Nominal Bore Pipe inch	O.D. of Pipe / Tube / Hose inch
A1	6		
	6.4		1/4
	8		5/16
	9.5		3/8
	10	R 1/8	
	12		
	12.7		1/2
	13.5	R 1/4	
	14		
	15		
16		5/8	
17.2	R 3/8		
18			
A2	19		3/4
	20		
	21.3	R 1/2	
	22		7/8
	25		
	25.4		1
	26.9	R 3/4	
	28		
	30		
	A3	30	
32			1 1/4
33.7		R 1	
35			
38			1 1/2
40			
42		R 1 1/4	
A4	38		1 1/2
	42		
	44.5		1 3/4
	48.3	R 1 1/2	
	50.8		2
	55		2 1/4
	57		
	60.3	R 2	
	63.5		2 1/2
	65		
70		2 3/4	

Ölçü Tablosu	Sipariş Kodu
Dimension Table	Order Code
GxL	
M10x45 3/8-16 UNC x 1-3/4	CCAM3010045 CCAC3012045
M10x60 3/8-16 UNC x 2-1/4	CCAM3010060 CCAC3012060
M10x70 3/8-16 UNC x 2-3/4	CCAM3010070 CCAC3012070
M12x100 7/6-14 UNC x 4	CCAM3012100 CCAC3014100

Ölçü Tablosu					Sipariş Kodu
Dimension Table					Order Code
L1	L2	L3 min.	G	SW	
49	24	15	M10 3/8-16 UNC	15	CCBM3010024 CCBC3012024
65	40	15	M10 3/8-16 UNC	15	CCBM3010040 CCBC3012040
74	50	15	M10 3/8-16 UNC	15	CCBM3010050 CCBC3012050
108	81	18	M12 7/16-14 UNC	17	CCBM3012081 CCBC3014081

Metal + Kaplama Tipi Metal + Surface Finishing		Vida Tipi Thread Type	
0	Kaplamasız / Uncoated	C	UNC
1	Fosfat / Phosphated / Fe/Znph	F	UNF
3	Galvaniz / Galvanized / Fe/Zn 8C Cr3-B	M	Metrik / Metric
4	CrNi 304 AISI 304	W	Whitworth
6	CrNi 316 AISI 316		
9	Çinko Nikel / Zinc Nickel / Fe/ZnNi		

Farklı malzeme talepleriniz için lütfen LMC Makina'ya danışınız.

For different material request please consult LMC Makina.

**Altıköşe Başlı Cıvata**  
Hexagon Head Bolt

DIN 931 / 933 - ISO 4014

C	C	A	M	3	0	1	0	0	4	5
			Vida Tipi Thread Type			Vida Ölçüsü Screw-Bolt Size				Cıvata Boyu Screw-Bolt Length

**Ara Bağlantı Cıvatası**  
Stacking Bolt

C	C	B	M	3	0	1	0	0	2	4
			Vida Tipi Thread Type			Vida Ölçüsü Screw-Bolt Size				Cıvata Boyu Screw-Bolt Length

Grup Group	Dış Çap (ØD) O.D. of Pipe / Tube/Hose mm	Anma Çapı (R) Boru Dış Nominal Bore Pipe inch	Dış Çap (ØD) O.D. of Pipe / Tube/Hose inch
A5	65		
	70		
	73	R 2 1/2 <small>except DIN EN 10220</small>	2 7/8
	76.1	R 2 1/2 <small>only DIN EN 10220</small>	3
	80		
A6	82.5		3 1/4
	88.9	R 3	3 1/2
	88.9	R 3	3 1/2
	100		
	101.6	R 3 1/2	4 1/4
A7	108	R 4	4 1/4
	114.3		
	127		5
	133		5 1/4
	133		
A8	139.7	R 5	6
	152.4		6 1/4
	159		6 1/2
	165		
	168.3	R 6	7
A9	177.8		7 5/8
	193.7		8 1/2
	216		
	219.1	R 8	
	219.1	R 8	
A10	244.5		
	273	R 10	
	323.9	R 12	
	355.6	R 14	
	406.4	R 16	

Ölçü Tablosu Dimension Table	Sipariş Kodu Order Code
GxL	
M16x130 5/8-11 UNC x 5-1/4	CCAM3016130 CCAC3020130
M20x190 3/4-10 UNC x 7-1/2	CCAM3020190 CCAC3024190
M24x220 7/8-9 UNC x 8-3/4	CCAM3024220 CCAC3028220
M30x300 1-1/8-7 UNC x 12	CCAM3030300 CCAC3104300
M30x450 1-1/8-7 UNC x 17-1/2	CCAM3030450 CCAC3104450
M30x560 1-1/8-7 UNC x 22	CCAM3030560 CCAC3104560

Ölçü Tablosu Dimension Table					Sipariş Kodu Order Code
L1	L2	L3 min.	G	SW	
144	110	24	M16 5/8-11 UNC	21	CCBM3016110 CCBC3020110
200	151	30	M20 3/4-10 UNC	27	CCBM3020151 CCBC3024151
240	180	50	M24 7/8-9 UNC	30	CCBM3024180 CCBC3028180
331	256	62	M30 1-1/8-7 UNC	46	CCBM3030256 CCBC3104256

Metal + Kaplama Tipi Metal + Surface Finishing		Vida Tipi Thread Type	
0	Kaplamasız / Uncoated	C	UNC
1	Fosfat / Phosphated / Fe/Znph	F	UNF
3	Galvaniz / Galvanized / Fe/Zn 8C Cr3-B	M	Metrik / Metric
4	CrNi 304 AISI 304	W	Whitworth
6	CrNi 316 AISI 316		
9	Çinko Nikel / Zinc Nickel Fe/ZnNi		

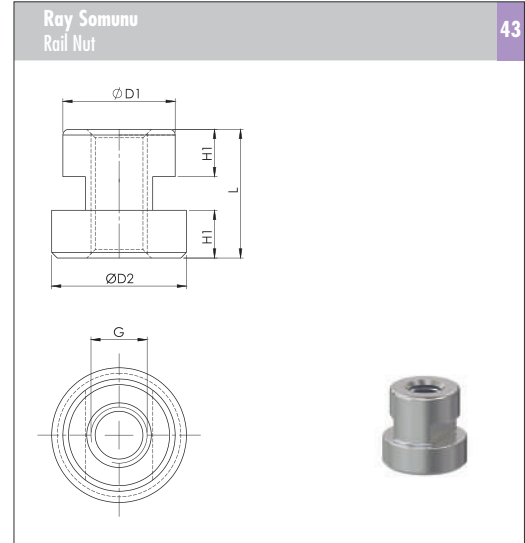
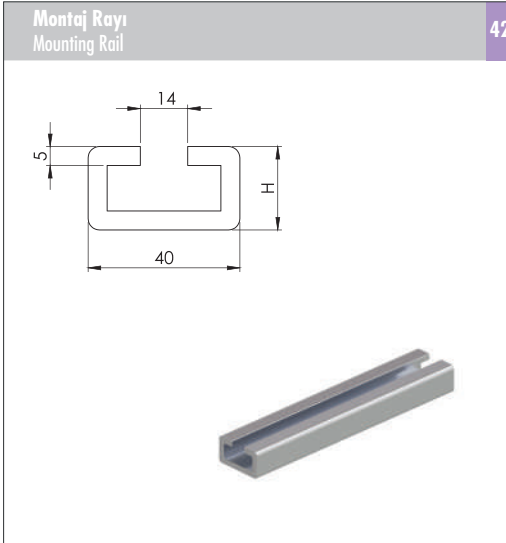

Farklı malzeme talepleriniz için lütfen LMC Makina'ya danışınız.

For different material request please consult LMC Makina.

C	R	Y	0	2	2	4	0	1
			▼ Metal + Kaplama Tipi Metal + Surface Finishing			▼ Vida Ölçüsü Screw-Bolt Size		▼ Boy Length

C	R	S	2	M	3	0	1	0
			▼ Tip Type	▼ Vida Tipi Thread Type	▼ Metal + Kaplama Tipi Metal + Surface Finishing		▼ Vida Ölçüsü Screw-Bolt Size	

Grup	Dış Çap (ØD)	Anma Çapı (R) Boru Dış	Dış Çap (ØD)
Group	O.D. of Pipe / Tube / Hose mm	Nominal Bore Pipe inch	O.D. of Pipe / Tube / Hose inch
A1	6		
	6.4		1/4
	8		5/16
	9.5		3/8
	10	R 1/8	
	12		
	12.7		1/2
	13.5	R 1/4	
	14		
	15		
16		5/8	
17.2	R 3/8		
18			
A2	19		3/4
	20		
	21.3	R 1/2	
	22		7/8
	25		
	25.4		1
	26.9	R 3/4	
	28		
	30		
	A3	30	
32			1 1/4
33.7		R 1	
35			
38			1 1/2
40			
42	R 1 1/4		
A4	38		1 1/2
	42		
	44.5		1 3/4
	48.3	R 1 1/2	
	50.8		2
	55		
	57		2 1/4
	60.3	R 2	
	63.5		2 1/2
	65		
70		2 3/4	

Ölçü Tablosu		Sipariş Kodu
Dimension Table		Order Code
H	Boy / Length	
22	1 m 2 m	CRY022401 CRY022402

Ölçü Tablosu					Sipariş Kodu
Dimension Table					Order Code
L	H1	ØD1	ØD2	G	
21	7.5	17.8	24	M10 3/8-16 UNC	CRS2M3010 CRS2C3012
23	8.5	19.8	24	M12 7/16-14 UNC	CRS2M3012 CRS2C3014